



June 2000

41

Enhancing the Political Feasibility
of Health Reform:

The Mexico Case

Enhancing the Political Feasibility
of Health Reform:

The Mexico Case

Alejandra González Rossetti, M.Sc., M.P.A.
Harvard School of Public Health

Olivia Mogollon

June 2000

This publication was produced by the Data for Decision Making (DDM) project, funded by the U.S. Agency for International Development under Cooperative Agreement No. DPE-5991-A-00-1052-00 with the Harvard School of Public Health. It was done in collaboration with the Latin America and Caribbean Regional Health Sector Reform Initiative, funded by USAID under Contract No. HRN-5974-C-00-5024-00.

The opinions expressed herein are those of the authors and do not necessarily reflect the views of the U.S. Agency for International Development.

TABLE OF CONTENTS

ACRONYMS	ii
INTRODUCTION	1
POLITICAL AND ECONOMIC CONTEXT	1
POLICY PROCESS	4
CHANGE TEAMS AND OTHER POLITICAL STRATEGIES	9
I. POLITICAL ECONOMY CONTEXT	12
THE MEXICAN POLITICAL SYSTEM.....	12
RESTRUCTURING THE POLITICAL SYSTEM.....	29
II. POLICY PROCESS	40
BACKGROUND	40
THE HEALTH SECTOR REFORM PROGRAM (PRSS)	45
SOCIAL SECURITY REFORM	47
IMSS REFORM OBJECTIVES.....	49
PROBLEM DEFINITION AND REFORM FORMULATION (1992-94)	49
THE ECONOMIC TEAM AND THE IMSS CHANGE TEAM.....	50
OTHER GROUPS IN THE STATE AND IN SOCIETY	55
LEGISLATION (NOVEMBER/DECEMBER 1995)	62
APPROVAL IN CONGRESS	63
IMPLEMENTATION (1996 – 1998)	66
ANOTHER ATTEMPT AT HEALTH REFORM.....	67
CLOSING REMARKS: KEY POLICY NODES AND ACTORS.....	69
III. CHANGE TEAMS AND OTHER POLITICAL STRATEGIES	71
THE ECONOMIC CHANGE TEAM	71
THE CHANGE TEAM WITHIN IMSS.....	80
THE EXECUTIVE’S INTER-AGENCY HEALTH CARE GROUP	81
CONCLUSIONS	84
ANNEX I: POLICY TRACER	85
I. INTRODUCTION.....	85
II. BACKGROUND	86
III. ANALYSIS OF THE HEALTH COMPONENT OF THE IMSS BY POLICY TRACERS	91
IV. CONCLUSIONS	104
BIBLIOGRAPHY	106
I. POLITICAL ECONOMY CONTEXT.....	106
II. POLICY PROCESS.....	110
III. CHANGE TEAM AND OTHER POLITICAL STRATEGIES.....	113

ACRONYMS

Acronym (Terms)	Spanish	English Translation	
ABM	Asociación de Banqueros de México	Mexico's Bankers Association	Business Association
AMCB	Asociación Mexicana de Casas de Bolsa	Mexican Brokerage Houses Association	Business Association
AFORE	Administradora de Fondos para el Retiro	Pension Funds Administrator	Private
AMCB	Asociación Mexicana de Casas de Bolsa	Mexican Brokerage Houses Association	Business Association
AMDG	Áreas Médicas de Gestión Desconcentrada	Deconcentrated Medical Areas	
AMIS	Asociación Mexicana de Instituciones de Seguros	Mexican Association of Insurance Institutions	Business Association
CAMCO	Cámara Americana de Comercio	American Chamber of Commerce	Business Association
CANACINTRA	Cámara Nacional de la Industria de la Transformación	National Chamber of Transformation Industry	Business Association
CANCO-MEX	Cámara Nacional de Comercio de la Ciudad de México	Mexico City's National Commerce Chamber	Business Association
CCE	Consejo Coordinador Empresarial	Business Coordinating Counsel	Business Association
CEDESS	Centro de Desarrollo Estratégico para la Seguridad Social	Strategic Development Center for Social Security	Private
CGT	Confederación General de Trabajadores	General Workers' Confederation	Union
CMHN	Consejo Mexicano de Hombres de Negocios	Mexican Businessmen Counsel	Business Association
CNA	Consejo Nacional Agropecuario	National Agricultural Counsel	Business Association
CNC	Confederación Nacional Campesina	National Peasant Confederation	Peasants Union/PRI
CNG	Confederación Nacional Ganadera	National Cattle Raising Confederation	Business Association

CNOP	Confederación Nacional de Organizaciones Populares	National Confederation of Popular Organizations	Public/PRI
CNPC	Confederación Nacional de Cámaras de Pequeño Comercio	National Confederation of Small Commerce Chambers	Business Association
CNPP	Confederación Nacional de la Pequeña Propiedad	National Small Property Confederation	Business Association
CNSF	Comisión Nacional de Seguros y Fianzas	National Commission of Insurance and Bail Bonds.	Public
CONAPO	Consejo Nacional de Población	National Population Council	
CONCAMIN	Confederación de Cámaras Industriales	Confederation of Industrial Chambers	Business Association
CONCANACO	Confederación de Cámaras Nacionales de Comercio	Confederation of National Commerce Chambers	Business Association
CONSAR	Comisión Nacional del Sistema de Ahorro para el retiro	National Committee for the Retirement Savings System	Public
COPARMEX	Confederación Patronal de la República Mexicana	Mexican Republic Employers Confederation	Business Association
COR	Confederación Obrera Revolucionaria	Revolutionary Labor Confederation	Union
CROC	Confederación Revolucionaria de Obreros y Campesinos	Revolutionary Confederation of Workers and Peasants	Union
CROM	Confederación Revolucionaria de Obreros de México	Mexico's Workers Revolutionary Confederation	Union
CROM	Confederación Revolucionaria de Obreros de México	Mexico's Workers Revolutionary Confederation	Union
CT	Congreso del Trabajo	Workers Confederation	Union
CTM	Confederación de Trabajadores de México	Mexico's Workers Confederation	Union/PRI

CURP	Código Unico de Registro Poblacional	Code of Population Registration	
DALYS	Años de Vida Saludable (AVISA)	Daily Adjusted Life Years	
DDF	Distrito Federal	Federal District	
DIF	Instituto para el Desarrollo Integral de la Familia	System for the Integral Development of the Family	
DRGs	Grupos relacionados por diagnóstico	Diagnostic-related groups	
FAT	Frente Auténtico del Trabajo	Authentic Labor Front	Union
FDN	Frente Democrático Nacional	National Democratic Front	Political Party
FESEBES	Federación de Sindicatos de Bienes y Servicios	Federation of Goods and Services Unions	Union
FMI	Fondo Monetario Internacional	International Monetary Fond	Multilateral
FSTSE	Federación de Sindicatos de Trabajadores al Servicio del Estado	Federation of State Workers Unions	Union
FUNSALUD	Fundación Mexicana para la Salud	Mexican Health Foundation	Private
IMSS	Instituto Mexicano del Seguro Social	Mexican Institute for Social Security	Public
INFONAVIT	Instituto del Fondo Nacional para la Vivienda de los Trabajadores	National Institute for Workers Housing	Public
INSP	Instituto Nacional de Salud Pública	National Institute of Public Health	Public
ISSSTE	Instituto de Seguridad y Servicios Sociales de los Trabajadores del Estado	State Workers' Social Security and Services Institute	Public

ITAM	Instituto Tecnológico Autónomo de México	Mexican Technological Autonomous Institute	Private
IVCM	Seguro de Invalidez, Vejez, Cesantía en Edad Avanzada y Muerte	Pensions Insurance	
MIAIS	Modelo Institucional de Atención Integral de la Salud	Institutional Model for Comprehensive Health Services	
PAHO	Organización Panamericana para la Salud	Pan-American Health Organization	Multilateral
PAN	Partido Acción Nacional	National Action Party	Political Party
PARM	Partido Auténtico de la Revolución Mexicana	Authentic Party of the Mexican Revolution	Political Party
PFCRN	Partido del Frente Cardenista de Reconstrucción Nacional	Cardenista Front for National Reconstruction Party	Political Party
PMT	Partido Mexicano de los Trabajadores	Mexican Workers' Party	Political Party
PPS	Partido Popular Socialista	Popular Socialist Party	Political Party
PRD	Partido de la Revolución Democrática	Democratic Revolution Party	Political Party
PRI	Partido Revolucionario Institucional	Institutional Revolutionary Party	Political Party
PRM	Partido de la Revolución Mexicana	Mexican Revolution Party	Political Party
PROGRESA	Programa de Educación, Salud y Alimentación	Education, Health and Nutrition Program	
PRONASOL	Programa Nacional de Solidaridad	National Solidarity Program	
PRSS	Programa de Reforma del Sector Salud	Health Sector Reform Program	

PSUM	Partido Socialista Unificado de México	Mexico's Unified Socialist Party	Political Party
PT	Partido del Trabajo	Labor Party	Political Party
SAR	Sistema de Ahorro para el Retiro	Retirement Savings System	
SCNS	Sistema Nacional de Cuentas de Salud	National Health Accounts System	
SECODAM	Secretaría de la Contraloría y Desarrollo Administrativo	Comptroller's Office	Public
SECOFI	Secretaría de Comercio y Fomento Industrial	Commerce Ministry	Public
SEM	Seguro de Enfermedades y Maternidad	Illness and Maternity Insurance	
SEMIP	Secretaría de Energía Minas e Industria Paraestatal	Energy, Mining and Public Enterprises Ministry	Public
SEPAFIN	Secretaría de Patrimonio y Fomento Industrial	Ministry of Patrimony and Industrial Promotion	Public
SHCP	Secretaría de Hacienda y Crédito Publico	Finance Ministry	Public
SINDAS	Sistema de Incentivos al Desempeño en Areas de Salud	Performance Incentives System for Healthcare personnel.	
SME	Sindicato Mexicano de Electricistas	Electricians' Mexican Union	Union
SNCS	Sistema Nacional de Cuentas de Salud	National Health Accounts System	
SNTE	Sindicato Nacional de Trabajadores de la Educación	National Union of Education Workers	Union
SNTSS	Sindicato Nacional de Trabajadores del Seguro Social	National Union of Social Security Workers	Union
SPP	Secretaría de Programación y Presupuesto	Planning Ministry	Public
SRT	Seguro de Riesgos de Trabajo	Work Hazard Insurance	

SSA	Secretaría de Salubridad y Asistencia	Health Ministry	Public
SSF	Seguro de Salud para la Familia	Family Health Insurance	
SSPEMEX	Servicios de Salud de PEMEX	Health Services for Oil Workers	Public
SSSD	Servicios de Seguridad y Salud del Ejército	Health Services of the Army	Public
SSSM	Servicios de Seguridad y Salud de la Marina	Health Services for the Navy	Public
STERM	Sindicato de Trabajadores Electricistas de la República Mexicana	Electrical Workers' Union	Union
STFRM	Sindicato de Trabajadores Ferrocarrileros de la República Mexicana	Railroad Workers' Union	Union
STPRM	Sindicato de Trabajadores Petroleros de la República Mexicana	Oil Workers Union	Union
STPS	Secretaría del Trabajo y Previsión Social	Labor Ministry	Public
STRM	Sindicato de Telefonistas de la República Mexicana	Telephone Workers' Union	Union
UNAM	Universidad Nacional Autónoma de México	Mexico's National Autonomous University	Public
UNT	Union Nacional de Trabajadores	National Workers' Union	Union

INTRODUCTION

For almost two decades, several countries in the Latin American Region have been engaged in a process of State reform with consequences for their social, political, and economic spheres. In the case of the health sector, there has been a growing consensus among policy makers, providers, and users about the need for structural change. But there has been no similar shared understanding of what the content of a health reform agenda might be. The definition of the problems to be solved, the means to solve them, as well as the speed and scope of policy change continue to be contentious issues. As a result, the political dimension of health reform formulation and implementation has come to the foreground as it has proven to be a key factor in determining the feasibility of health policy change as well as its final outcome.

The present study is a careful analysis of the political context and the policy process within which health reform initiatives evolved in Mexico, as well as of the actors involved. It is designed to bring to light important lessons about the political strategies that have been put in motion by policy makers interested in increasing the political feasibility of health reform efforts. The analysis of the initiative to reform the health component of social security in Mexico in the mid-nineties contributes to the discussion about the effectiveness of the strategies used by teams of reformers. It also helps to exemplify how strategies change and adapt to dynamic and constantly evolving political and economic contexts. Finally, it enriches the debate regarding the use of change teams to bring about comprehensive reforms in the provision of public services.

POLITICAL AND ECONOMIC CONTEXT

A distinctive characteristic of the political system in Mexico is the concentration and centralization of power in the Executive branch of government, specifically in the President. The Constitution grants the Executive a series of formal attributes —such as the prerogatives to send law initiatives to Congress, to veto congressional resolutions, and choose the House of Congress to which policy initiatives are sent in first instance—that strengthen the Executive branch as the center of policy making.

The Executive's power is not only based on the formal attributes granted by the Constitution. A series of informal faculties have allowed the Presidency to become the single most important source of legislation. This practice, in place for more than half a century, has transferred the policy decision-making and negotiation to arenas outside the public scrutiny, such as the ruling party or the Executive itself.

However, the Presidency's informal powers have weakened as a consequence of the democratic opening. Since 1997, when the PRI lost its majority in the Lower House for the first time, the government has had to negotiate with opposition parties in order to gain approval of its law initiatives. Also, given the more competitive political environment, the Executive has had to step up its negotiations with its own party, since the legislators' incentives to back unpopular policy initiatives have greatly diminished.

A second relevant characteristic of the Mexican political system is the rather weakened, but still present, corporatist arrangement that rules the relations between the State and different social sectors through the official political party—the Institutional Revolutionary Party (PRI). The corporatist arrangement between the State and society rests on a set of implicit agreements that govern the access to policy-making and the distribution of public goods and services. This

arrangement between the State and society has rested on the exclusive inclusion of organized social groups mostly working in the formal economy. In exchange for organized political support, the incorporated sectors receive from the State privileged access to public goods and services. The Mexican Institute for Social Security (IMSS) is the largest and most visible example of the institutionalization of this arrangement.

Three social groups stand out as sources of political support due to their economic weight and their mobilization capacity: the business community, the labor movement, and the government bureaucracies. The business community is not a formal part of the ruling party, but it is also organized in a corporatist manner with specialized associations. While this group does not resort to collective mobilization, it has represented an important source of support for the State and has also exerted veto power due to its control over the financial and industrial sectors. The business elite, which includes the mass media, has been able to establish direct channels of access to high level public officials. This has allowed businessmen to have direct influence over policy making.

Organized labor has functioned since its incorporation into the ruling party in the mid-thirties, as the most important base of political support for the State. Official unions have been the intermediaries in the relation between the State and labor. Currently the largest union in Mexico, and one of the most articulated ones, is the IMSS union (SNTSS). This union has a membership totaling 350,000, including virtually all of health manpower, as well as other non-medical workers and administrative personnel of IMSS across the country. Its political role in the past, its liaisons with the PRI, as well as its more independent discourse in the last decade, makes it an important interlocutor of policy makers seeking to pursue major changes related to social security.

Finally, the State's lower-level bureaucracy is also unionized and has also resorted to its unions to exchange political support for exclusive access to public goods and services. High and mid level officials are not unionized and resort to their own support networks, or *camarillas*, to secure their jobs, concentrate power and pursue their political careers.

The corporatist arrangement described above prevailed for almost 50 years since the PRI's consolidation in the 1930s. It greatly influenced policy choice in both the economic and the social spheres. In the case of the social sector, the social security system, and as a consequence, the health sector as a whole, reflect the configuration of the corporatist arrangement and its political use of public resources and policies. The health system in Mexico still reflects the political arrangement between the State and those actors it considered politically or economically relevant, to whom access to social security services were granted. It excluded those groups with little capacity for political mobilization and whose economic activities were centered in the informal sector, notably the poor. To the latter group, the State provides under-funded and insufficient health care through the Ministry of Health facilities.

With the economic boom and the growth of the middle class, this political arrangement began to be contested in the mid-1960s. The political crisis that resulted from the repression of the 1968 student movement, marks the start of a long and protracted political liberalization process in which society has pressed to have a say in decision making and has questioned the corporatist arrangement. This process was to result in more democratic formal mechanisms for elections in the late 1980s, and the activation of opposition parties that for the first time faced real possibilities of sharing in power and alternating in office. The 1980s also mark the exhaustion of the political elite that had been ruling over a closed statist economy for decades, and the arrival in power of a different breed of policy makers: the neo-liberal technocrats. Their seizure of power was possible due to the legitimacy crisis that the PRI's traditional politicians

(and their keynesian economists) were facing due to the recurrence of ever more acute economic crises which surpassed—at least in the popular perception—the traditional politicians' capacities. Simultaneously, due to economic stagnation, the State was unable to create formal jobs for an ever-growing population with a larger group of young adults, who therefore had to turn to the informal economy.

The 1980s debt crisis and the consolidation in power of the neo-liberal technocracy were determinant events in the economic adjustment measures that were to follow, as well as in the structure of State-society relations. The magnitude of the economic crisis led policy makers to question the economic model in force. The technocratic group profited from this window of opportunity to consolidate itself in power and to pursue policy reforms that were to redefine the economic model, the role and size of the State, as well as State-market and State-society relations.

Seeking to limit State control over policy and the markets, and perceiving its exhaustion, this group of policy makers in power questioned the corporatist political arrangement and severely undermined it. However, this radical transformation in State-society relations was not going to happen in all policy areas simultaneously. The most significant changes occurred in the economic sphere, where market liberalization was completed. Public enterprises were put up for sale and, in some instances, State bureaucracy was trimmed down. Social sector reform—which was also part of the technocracy's agenda, if a less important one—had a very slow start and left the old corporatist arrangements and actors virtually untouched. Thus, social sector unions, notably the IMSS union, not only survived State reform, but were actually useful in securing the political support needed to pursue reforms in other sectors.

The group of technocrats that gained strength within government in the early 1980s under De la Madrid's administration was a cohesive team comprised of technically skilled individuals whose political careers had developed almost entirely in the financial and economic agencies of government. Most of them lacked electoral or party experience. The increase in the technocratic group's influence corresponded to a decrease in power of traditional PRI politicians and union leaders. It also meant the displacement of keynesian economists from high government positions.

The arrival of Carlos Salinas to the Presidency in 1988, marks the consolidation of the neo-liberal technocrats in power. President Salinas' cabinet was even more homogeneous and technical than that of president De la Madrid. It was a close and cohesive elite, with roots in the Ministries of Finance and Planning that extended to other government agencies and monopolized policy-making. This technocratic team furthered the policy agenda that prioritized economic liberalization and the downsizing of the State, particularly the privatization of public firms and services. Major structural adjustment was to follow and Mexico was to join the world market by opening its markets and joining NAFTA.

However, macroeconomic changes failed to provide tangible benefits to the majority of the population who still resented the impact of the economic crisis. Furthermore, the economic reform negatively affected interest groups that had played an important role in State-society relations for decades. The enormous pressure on the political system that resulted from these factors undermined the *modus operandi* of the last 60 years, notwithstanding its corporatist arrangement. The lack of financial resources limited the State's capacity to maintain the exchange of public goods and services for the organized political support of the corporatist sectors. It also prevented the State from incorporating the newly mobilized social groups, most of which worked in the informal economy, into the old corporatist pact.

Paradoxically, the technocrats who had sought to limit the scope of action and even dismantle the corporatist machinery, had to turn to it in order to promote and consolidate their structural adjustment agenda. Thus, the technocracy in power was careful not to tamper with the political machinery or corporatist interests in those areas that were not a priority in their policy agenda, but that played an important role in securing political support for the government and maintaining the overall political system's stability.

In spite of these efforts, the erosion of the corporatist arrangement undermined the ties between the State and the official unions and favored the strengthening of independent unionism. Official labor unions were not capable of protecting the interests of their membership, nor were they immune to the incentives this new environment. They had to take a more confrontational position *vis a vis* the State in order to continue to secure their veto power. The IMSS union is an example of these changes of strategy in negotiations with the State. Having obtained all its benefits from its unconditional support to the State and the PRI, it recently turned to a more independent discourse particularly as the technocratic policy makers turned their attention to reforming IMSS once they had completed their task in the economic sector.

At the end of the Salinas administration, the need to reconstruct the political network and to reconcile groups affected by the economic crisis and the adjustment policies that followed, was evident. At the same time, the consolidation of the economic reforms that had been implemented during the eighties and nineties was a priority for technocrats. President Salinas found in Luis Donaldo Colosio a presidential candidate who ensured policy continuity and at the same time was able to reconstruct the links with political actors.

Colosio's assassination and the emergence of the Zapatista guerrilla movement in Chiapas in 1994, brought about a political crisis that seriously compromised the technocratic group's policy agenda of policy change and continuity in its direction. In the power struggle that followed immediately after Colosio's death, President Salinas was forced to select a presidential candidate who, being a technocrat from the Central Bank and the Ministry of Planning, could ensure policy continuity, but had no political credentials. Thus, Zedillo counted on very little political capital to go beyond the consolidation of the economic reform and into other policy areas, such as the social sector – including health.

The liquidity crisis that occurred at the end of 1994 further complicated the prospects of the technocratic group in power. Ernesto Zedillo's government had to increase taxes to balance public finances. The political cost of promoting these reforms was so high that the government's margin of maneuver was considerably reduced. Nonetheless, he promoted the reform of the pensions system as a preventive measure against its imminent bankruptcy, and as a way to raise internal savings. But President Zedillo opted to reduce his reform agenda and focus on stabilizing the country politically and economically. This explains in part why the Zedillo administration was reactive rather than proactive regarding the implementation of policy change. This position was to have an important impact in the health reform agenda. The priority given to pensions reform as part of the economic policy package, and the need to reduce potential political confrontation with organized groups such as the IMSS union, severely limited the political feasibility of an in-depth health reform that would necessarily affect entrenched interests

POLICY PROCESS

The health system's institutional configuration reflects the corporatist arrangement described above, insofar as the provision of health services is perceived as an exchange between State and society. The capacity of different groups to obtain more and better health services

depends on their income, their occupation and position within the social strata, and their capacity for political organization. Under this arrangement, health and social services are focused primarily on the urban industrial workers who are members of the official confederations and other strategic groups such as oil workers, the army, the navy, and the bureaucracy. Non-mobilized groups working in the informal economy, particularly those in the rural sector, have access to second-rate public health services and in remote areas, to no services at all.

The weakening of the corporatist pact following the economic crisis of the mid-eighties, led to an effort by the Salinas government to rebuild—or reconfigure—the State's coalition of support. It tried to incorporate those groups that, being in the informal sector, were marginalized both from political participation and public services, including those of the social sector, particularly social security. To do so, and to circumvent the vested interests entrenched in the social sector's bureaucracy, it established new social programs (under the umbrella program called PRONASOL) aimed at poverty alleviation and local development through the mobilization of the target population and participatory schemes. The unifying characteristic of these program's target groups was that they had been excluded from the old corporatist pact, and thus had little access to the public services and goods that were channeled to formal organized social groups in exchange for their political support. However, in spite of the establishment of fresh exchange channels between the State and these new politically mobilized groups, the technocracy in power perceived the need to maintain some of the bastions of the old corporatist arrangement in order to secure enough political stability to pursue its economic reform agenda. This explains why, in spite of this wave of new of State-society relations in the social sector, President Salinas decided not to reform the IMSS, the most visible representation of the corporatist pact.

This did not mean, however, that the reform of IMSS, along with that of the rest of the social sector, ceased to figure in the technocracy's agenda. The IMSS was regarded by the economic team as a large government agency in financial difficulties that needed to be reformed. Not only did it face bankruptcy—to which the State would have to respond, but it was soon to fail to meet its pensions commitments with workers that were about to retire. Responding to what was seen as an imminent crisis, policy makers of the economic team who were heading the Finance and Commerce ministries started studying the case and formulating proposals in the early 1990s. The IMSS issue was important enough to become one more element of competition between the *camarillas* in this economic team, who were positioning themselves to compete for the presidential succession.

The resulting pensions reform proposal consisted in substituting the pay-as-you-go pensions system for a scheme of fully funded individual retirement accounts. Also, as part of the government's promotion of sound fiscal policies, the Finance Ministry decided to promote the financial reorganization of all the other insurance funds and benefits of the IMSS. Its sole objective was to guarantee the agency's financial equilibrium, and to induce a more efficient use of resources. When the Salinas administration was reaching its end, some of the members of the technocratic group that had gained control over the project were assigned to positions within IMSS to pursue the reform process and prepare for implementation in view of the change of administrations.

Simultaneously, the IMSS directorate created a think tank (CEDESS) that was assigned the responsibility of studying policy options and to formulate a more integral reform proposal that went beyond the financial restructuring of the Institute, and included an in-depth change in health service delivery. This initiative had the double purpose of presenting a technocratic proposal in similar terms to that being prepared by the economic team in the Executive and thus

facilitate closer links with this group, and to have the IMSS reform process gravitate back to IMSS control. In spite of some exchanges and joint efforts between this group and the economic team working within the Executive, this attempt failed. The IMSS directorate was only given a major role when the Executive had to broker its reform proposal with the different interest groups and with Congress.

Also in the light of the imminent change of administrations, and with the aim of influencing policy decision making in this field, non-governmental groups, as well as policy makers in the Ministry of Health set about preparing health policy proposals. These groups, some of which were positioning themselves to compete for positions in the Ministry of Health, included an academic group at the Mexican Autonomous University (UAM), that supported a single health care system with all costs being assumed by the State; a group coordinated by the SSA Planning undersecretary, Jaime Sepulveda, who conducted a series of polls to build a data base for a health reform plan; and the non-government-organization, Funsalud, that conducted a two-year project called Health and Economy led by Julio Frenk. The latter was to produce a comprehensive health sector proposal that envisioned major changes in both the Ministry of Health and the IMSS. These changes included the establishment of a single system with a plurality of public and private health service providers, in which the Ministry of Health would be responsible for policy guidelines and regulation, while the IMSS would be in charge of health service financing.

While the groups led by Sepulveda and Frenk had numerous contacts with the technocratic teams working on the issue in the Finance Ministry, and later on with those in the Zedillo campaign team, policy decision making remained firmly in the hands of the economic team. Thus, while many of the ideas in Funsalud's proposal permeated the national health reform program of the Zedillo government, and some are in the process of being implemented – notably the completion of the Ministry of Health services decentralization -, the thrust of the reform efforts in the health component of IMSS, remained focused on the financial aspects, that were the concern of the technocratic group related to the economic team. The CEDESS had a token initiative included in the policy reform package for IMSS' health component: one relating to an integrated model of health service delivery (MIAIS).

The rest of the policy changes aimed at reforming the IMSS health services had two common characteristics that relate them to the economic team's social sector reform agenda. First, all of them can be considered as an extension of the financial restructuring of IMSS insurance funds into the daily operative process of IMSS health services; and second, they all follow the principles used by the technocratic team in social sector reform – rationalization of expenditures, focalization, and performance incentives. Also, as opposed to the pension reform, most of the policy changes related to the health component could be pursued through administrative acts and decrees internal to IMSS, without the need to amend the Social Security Law. This meant that there were few institutional requirements for consultation and the participation of interest groups in the field, and that its timing did not have to abide by the legislative calendar.

The final reform package of IMSS' health component included the following elements:

- Financial restructuring
- Deconcentration and rationalization of the IMSS
- Institutional model for comprehensive health services (MIAIS)
- Medical areas for deconcentrated management (AMGD)
- Family health insurance (SSF)

- Family doctor eligibility and performance incentives in family health care centers
- Performance incentives
- Costing according to diagnosis-related groups (DRGs)
- Contracting-out of health services

It can be argued that six out of the nine reform components are related to the rationalization of resource management for the sake of a more efficient use of the latter. At the same time, many of these policy proposals were linked with the Zedillo administration's health reform program. This was most notable in the case of the creation of the Family Health Insurance, which aimed at expanding the social security's health component coverage through a health insurance scheme for workers in the informal economy with purchasing capacity. The other element that ran along the lines of the health reform program was the creation of the AMGDs, since this was a decentralization effort parallel to that of the Ministry of Health services.

The controversial reform initiative related to the systematic application of the opt-out option—in which businesses could procure private health services for their employees and have their mandatory quotas reimbursed, instead of using IMSS facilities—was not included in the reform package. Instead, it was included in the series of amendments to the Social Security Law that the Executive submitted to Congress for the pension reform. While the old Social Security Law already contemplated the opt-out option, and indeed it has been applied, if in very few exceptions, either a legal amendment or a regulatory body is needed for a more systematic and predictable use of this option. The issue has been highly contentious and has immediate political connotations, since both those who support the measure—particularly the business community—and those who oppose it—the union—see it as a means to dismantle the oversized IMSS apparatus and substitute for it with a more flexible public-private mix. In other words, it would significantly change IMSS' health services as they have been operating for the last half a century, since it would break the IMSS monopoly in service delivery for those affiliated with social security.

During the bargaining process in Congress for the approval of the new Social Security Law initiative, this amendment was dropped by the Executive when legislators, concerned with the IMSS union reaction, conditioned their vote of approval of the entire new Law, to the elimination of this modification. Given that the pension reform required a large amount of political capital, the technocratic team decided to diminish the number of points of confrontation with the largest union in the country. Also, the fact that the Social Security Law as it stood before the amendment initiative allowed—if in a vague manner—for the opt-out option as well as for the contracting-out of health services in particular circumstances. Therefore, reformers decided to pursue these issues through new regulations and administrative acts, thus avoiding the further politicization of the issues.

Genaro Borrego, the IMSS director, was given the task of negotiating the Executive's reform initiative with the labor sector, the business community, and IMSS union (SNTSS); and later on, to lobby for it in Congress. It was his political brokerage experience—as former PRI president, former governor, and PRI Senator—that provided political feasibility to the technocratic reform proposal prepared by the economic team within the Executive. In the Legislative arena, the SNTSS, the main actor lobbying against the reform proposal, was able to exert a significant degree of veto power through its influence on legislators unwilling to be at odds with organized labor. But this proved to be insufficient to veto the pension reform, which was a priority for the Executive.

The new Social Security Law was approved in Congress in 1995, and the pension reform implementation was started right away. A transitory article mandated that the rest of the reform begin implementation in 1997 to allow the Institute to prepare for change. Thus, the reform process gravitated back to the IMSS arena, where the reform package for the health component of social security was being formulated. The technocratic team in the IMSS working at the financial directorate, continued to work closely with its counterparts in the Finance Ministry, who were in charge of reforming the social sector, with Santiago Levy, the Expenditure Undersecretary, who was also in charge of social policy. But the economic and political crises, as well as the resignation of the Finance minister less than a month after taking office, who was the main source of political support of this change team, severely undermined its capacity for pursuing policy change.

While this did not bring the health reform to a halt, it did slow its implementation considerably, and give more leverage to the IMSS union, which allowed it to regain its position of force once the reform's implementation started. The team was forced to negotiate and look for consensus with the other groups within IMSS, noticeably the SNTSS, in order to implement its policy change initiatives. Moreover, because the health reform was not a priority on the Executive's agenda, and a potential labor conflict within the Institute is always a serious concern due to its immediate visibility, the IMSS directorate's support for the reform initiative was less than wholehearted.

In the most controversial issue, that of the opting-out option, temporary political support was going to stem from outside the IMSS. An *ad hoc* inter-agency group was put together within the Executive to study the need to regulate the private health sector and the emerging HMO market. Because of its relation with this policy issue, the long standing discussion about the possibility of establishing a more systematic opt-out option mechanism for IMSS affiliates was put back on the table.

Since 1996, this inter-agency group comprised of officials from the Presidency, the Finance Ministry, the Health Ministry, and the IMSS started to work on a project to simultaneously regulate quota reimbursement in IMSS and the health management organizations (HMOs) emerging market. In the end, once more, the possibility of a confrontation with the IMSS union, and its political consequences led the group to postpone the former and to carry on exclusively with the latter. Yet again, political considerations were not the only concern this group had when it decided to postpone the issue once more. The other reason behind not pursuing this line of policy change was the lack of documented proof that the implementation of the opt-out option and quota-reimbursement scheme was going to have a positive impact on the health system as a whole or that of IMSS' affiliates.

Furthermore, the interested actors in the business sector failed to present convincing evidence of the financial soundness of quota reimbursement for both parties, IMSS and the businesses, in light of the new Social Security Law. The new Social Security Law has significantly diminished the quota amount required of the business sector – by augmenting that of the government. This fact not only diminished the business sector's urgency for quota reimbursement, but strained the feasibility of paying for similar services to private providers with the reimbursement of the new quota. Also, the private health sector was not prepared to absorb a sudden increase in health services demand, since with few exceptions it is concentrated in the major urban centers, it continues to be a very desegregated market with very small unregulated providers scattered unevenly throughout the country.

As the Zedillo administration was coming to an end, the IMSS financial restructuring was well on its way. The significant increase in the government's quota participation—a result of the

new 1995 Social Security Law—restored IMSS' actuarial equilibrium. The technocratic team within IMSS, now heading the finance direction, managed to complete the financial reengineering of the insurance funds and benefits other than pensions, which have been privatized, thus eliminating cross-subsidies and making resource allocation more transparent. The Family Health Insurance scheme has been operating since 1997 and has affiliated 300,000 families. But it still needs to expand more aggressively if it is to meet the government's stated goal of expanding access to IMSS health services to all families with purchasing power who work in the informal sector. All the other policy changes in the IMSS health reform package (i.e. the integral model of health services delivery, AMDGs, family doctor eligibility, the use of performance incentives, DRGs and contracting out services) are still in the pilot phase under the close scrutiny of IMSS union leaders.

The analysis of the social security reform process, including the reform package for its health component, brings to light three major veto points. The main veto point is located within the Executive, during the period of policy formulation and competition among government agencies. All external actors, including the SNTSS, and to a great extent, the IMSS directorate proper, were excluded from this arena and precluded from participating in the decision-making process. The veto point located in the Executive was crucial to the health reform, since it was there that it was decided to approach it through regulation and administrative actions, rather than resorting to the amendment of the Social Security Law.

The second veto point is located in Congress, specifically in the Lower House, during the process of approval of new the Law. In this case, PRI legislators vetoed the amendment that sought to make a more systematic use of the opting-out option, as a condition to vote in favor of the pension system reform and the financial reorganization of other insurance funds and benefits. The IMSS union that opposed the modification of the article that regulates the opt-out option because it perceived it as a dangerous precedent for the privatization of the Institute, exerted pressure on legislators from different parties in order to have them veto the proposal.

In the Congress' spring adjournment, the Lower House approved an amendment to the Social Security Law that, if approved in the Upper House, would block even further IMSS' possibilities of using the opt-out option. This initiative was presented by the PRD (a left wing opposition party) on behalf of the SNTSS, and was approved with its votes and those of PAN (the right wing opposition party). The PRI voted against it, intending to use its majority in the Senate to block it in case it was submitted to the plenary.

Finally, the third veto point is located within the IMSS during the implementation period. In this arena, the SNTSS constitutes the principal veto group. The strength of the union is enough to control and in some cases block the change team's reform proposals. The change team, with no firm support from stronger factions in government, needs to negotiate any undertaking regarding policy change implementation. This has affected the speed and scope of the reform process and makes the implementation of an integral health reform very difficult.

CHANGE TEAMS AND OTHER POLITICAL STRATEGIES

As outlined above, economic reform in Mexico was promoted during the eighties and nineties, by a small group of technocrats whose careers were based in the financial and economic agencies of government. This team had ideological and programmatic cohesiveness. Its members shared a high level of technical training and a commitment to the principles of economic liberalism, even though they competed for political positions.

During the early nineties, a group of these technocrats from the Ministry of Finance and the Central Bank, led by Pedro Aspe, the Finance minister, developed a project to privatize the retirement pension system, which directly involved the IMSS. Because of its composition and ideological position, as well as its programmatic strategies, this team may be characterized as a change team. To be more precise, it could be characterized as a pension change team, since its mission and basic objectives were all defined around this policy issue. This group was forced to abandon the project in mid-1993 following a take over by a rival *camarilla* led by the President's Office along with the Commerce Ministry. From mid-1993 through 1994, this technocratic faction worked to develop a proposal for the reform of the pension system.

The economic team's strategy to pursue the pension reform followed the same pattern that had been used during the first generation reforms. A small change team of highly technical policy makers, foreign-trained and without professional experience at IMSS, was placed in formal positions within IMSS. Its coordination was assigned to Gabriel Martinez, a junior member of the Executive's economic team. In this way, the team in charge of implementing the financial reengineering of the IMSS and the reform of its health component, was an extension of the economic team. They were linked in a vertical network with the direct support of Jaime Serra Puche, who was to be named Finance Minister at the outset of the Zedillo administration. However, with the resignation of Jaime Serra Puche, this vertical link was to be broken and the IMSS change team was left without the political support of the core ministries. This event narrowed considerably its scope of action, slowing the pace of the IMSS reform. This fact was further aggravated by president Zedillo's decision to halt his support for any policy reform that was not directly related to solving the economic crisis.

On its side, the IMSS directorate also attempted to create a change team similar in nature and *modus operandi* to those used by the technocratic economic team in the core ministries, by forming the Strategic Development Center for Social Security (CEDESS) in mid-1993. The creation of CEDESS responded to Borrego's political strategy of establishing working links with the economic team, through a decision-making space outside the realm of the IMSS bureaucracy and its interest groups—notably the IMSS union. The IMSS director shared the perception that the creation of a technocratic change team formed with non-IMSS policy makers was an effective strategy to bring about policy change within a setting of resistance.

However, he was not successful in transforming CEDESS from a think-tank into a change team. The CEDESS group lacked a series of traits that are indispensable for the formation of a change team, such as ideological cohesiveness and a common reform agenda. But most significantly, it lacked vertical networks of support stemming from the core ministries. The economic change team did not recognize the group in CEDESS as a technocratic group of policy makers with the credentials to become a partner in IMSS reform. Furthermore, the CEDESS group did not have the horizontal networks with technocratic policy makers in other ministries, as Gabriel Martinez' team did – notably, with Santiago Levy, Finance undersecretary.

In addition to the change team assigned by the economic team to conduct IMSS reform from within, the economic cabinet mandated the creation of an inter-agency group to adjust and facilitate the negotiation of the pension reform project within the Executive proper. This inter-agency group formally served as an arena for the representation of the core agencies, but this was not its main objective. The representation function was subordinated to the concrete goal of adjusting and promoting the pension reform agenda. Thus, the team worked more as a task-force than a negotiation platform. It may not, however, be considered a change team because its responsibility only touched a very limited part of the reform: that of formulating the final form of the pension reform initiative to be presented in Congress. Also, none of its members was

assigned full time; instead, they continued with their regular activities in their respective agencies. Most impotently, the team was not empowered to broker the reform by itself be it within the Executive or with other interest groups outside it, and was only involved in the technical aspects of policy formulation.

In 1996, a year after the new Social Security Law was approved and the pensions inter-agency group had been dispersed, another inter-agency group was created within the Executive. This new group had the task of discussing the regulation of the emerging HMO market in the private health sector. While the group's initial goal was to simultaneously regulate the emerging HMO market along with the contracting-out of health services for IMSS and the controversial opt-out option, it perceived that tying the issues together could jeopardize the political feasibility of having the law amendment for HMOs approved in Congress. Thus, both issues relating to IMSS were postponed once again.

This health inter-agency group presents identical characteristics as that of the pensions inter-agency group. With a high technical profile, it also was not assigned the political maneuvering to broker the law initiative. This task was in fact not assigned for a long time, and was finally taken by Jose Antonio Gonzalez Fernandez, a week after he was appointed Health Minister. The group approached the reform as a regulation problem. This meant setting up the rules for, and creating new health providers: the HMOs. It thus avoided the reform proper of the existing provider institutions.

The analysis of the groups involved in the social security reform and its health component in Mexico shows that the technocratic characteristics of the last two administrations, led the Executive to use the same strategy it used to pursue reforms in the economic sector. It followed a very closed top-down approach. The participation of social groups and governmental agencies is restricted and entirely controlled by the Presidency and the core ministries, who, regardless of the policy issue, determine both the degree of participation and the composition of the group that is assigned the task of reform formulation. Also, due to the Executive's concentration of power, and the secondary role played by other arenas, Congress notwithstanding, these groups (change teams and inter-agency groups) find an ample space for policy definition only limited by the economic team's support and interest in the issue.

Following its experience with economic reforms, the economic change team created and empowered a change team with high technical skills, but little experience or ties with the social sector and particularly with IMSS. Once its members assumed formal positions within IMSS, the team centered its activities around the financial reengineering of the Institute. From this perspective, it sought to reform IMSS health services. However, the loss of its vertical network links with the economic team severely hampered its capacity to pursue change beyond those that were strictly financial. Beyond regulation and resource reallocations, the rest of the policy changes envisioned in the IMSS health services reform package to reform the operation of the health services proper, have reached the end of the Zedillo administration in a pilot phase and facing the constant veto of the SNTSS.

Thus, while the use of change teams in Mexico has proven its efficacy in inducing policy change through regulation and financial resource reallocation, it has failed to bring about the restructuring of public provider institutions like IMSS, thus severely limiting the scope of social sector reforms. In order to achieve the transformation of these old actors, interest groups that are normally excluded from the reform process need to be taken into consideration; either via consensus building or confrontation. So far, given their nature and position, change teams have been unable or unwilling to do either.

I. POLITICAL ECONOMY CONTEXT

During the Zedillo administration (1994-2000), a health reform program was formulated and presented as part of the government's six year policy agenda. Given the characteristics of the Mexican health care system, although the reform initiative considered the health sector as a whole, policy change was going to be implemented in two separate but parallel processes. One that would be undertaken by the Ministry of Health (SSA), and would concentrate on the decentralization of its health care services. The other would be implemented at the Mexican Social Security Institute (IMSS), and would concentrate on the financial reorganization of the Institute, with health care services being transformed as a secondary consequence under the same logic of efficiency and cost containment.

The present study focuses on the component of the IMSS reform that was also a part of the government's health sector reform. The central aspect of the former was the transformation of the public pension scheme to a private one, followed by the reform of the financial and operational elements of health service delivery at the IMSS. These two elements of IMSS reform are interrelated in terms of process. The IMSS health services officially represent 57% of the total population, and have operated along policy lines that reflect the country's political arrangement of the last seventy years. Therefore, the analysis of the attempt to transform the IMSS brings to light most of the aspects of the political economy of health reform—indeed social sector reforms in general—in Mexico. This initiative represents a convergence of the changing political context, the politics involved in the reform process proper, and the strategies used by reformers to bring about change.

The initiatives to reform IMSS' health component were formulated and attempted in a particular political and economic context. The characteristics of the Mexican political system include the formal and informal rules that determine the division of powers between the Executive, Legislative, and Judicial branches of government as well as the corporatist arrangement in State-society relations. A map of the relevant actors involved in public decision making is presented and the social actors most relevant to the specific arena of health reform are described in more detail. The chapter then presents the reconfiguration of the political system, stirred up by the economic crises of the eighties and nineties and the consolidation in power of a technocratic group of policy makers. It ends with an assessment of the social and political consequences of the system's restructuring and the options that the technocratic policy makers faced, when trying to secure the political support needed for their reform agenda.

THE MEXICAN POLITICAL SYSTEM

This section presents the aspects of the Mexican political system relevant for the political economy analysis of the IMSS health reform process. While it does not attempt a comprehensive overview of Mexico's modern political history, it does present the general framework in which policy decision making in the social policy area has occurred in the last seventy years, its major transformations in the last two decades, and their impact on the political feasibility of IMSS health reform initiative.

Structure

1 Division of Powers

The Republic of Mexico is formally constituted as a federal State and structured according to the principle of division of powers.¹ The concentration of formal and informal faculties in the Executive, however, has distorted the federal project and led to an over-centralization of power and an imbalance among the branches of government, in such a way that the Executive controls the Legislative and the Judiciary.²

The Mexican presidential republic was formally established in the 1917 Constitution,³ which determines that the Executive power should be concentrated in only one office, the President, and defines its powers. The Constitution contains few checks and balances on Executive power and those that do exist are limited. Thus, the Legislative and the Judicial branches have few mechanisms they can resort to in order to control the Executive.

While the 1917 Constitution established the formal principles that sustain the concentration of power in the Executive, and particularly on behalf of the President (which is denominated *presidencialismo*), it was not until the mid thirties that the president's power was institutionalized. That is, it was not for some years that the power of the Presidency became independent of the power and resources of the particular individual elected to be President. From that moment on, the Presidency was depersonalized and acquired power of its own, becoming an institution.

The decisive step towards the institutionalization of the Presidency took place in 1935, when President Lázaro Cárdenas confronted former President Plutarco Elías Calles, the highest informal political authority since 1924, even though his presidential term had ended in 1928. A few months after Cárdenas had assumed power in 1934, Calles held him responsible for a wave of strikes that were taking place in the country and threatened to withdraw his support and remove him from office. In view of this direct threat to his authority and in order to consolidate himself in power, President Cárdenas resorted to the organized labor movement he had indeed mobilized in the first place. Calles was defeated and his ten-year hold on power came to an end. He left the country in early 1936.

Thus, organized labor was incorporated to the official political party (named PRM at the time, but which was to be renamed PRI soon thereafter). Through this corporatist arrangement—between the State and official unions, under the rules of the former—the government secured organized political support from these groups, in exchange for privileged access to public goods and services. This relation was to be the pivotal anchor of State-society relations and a determinant factor for political decision making during the next fifty years. Although diminished in power and influence, it would continue to prevail until the turn of the 20th century.

¹ The Federation's power is divided in three branches of power: the Legislative branch, the Executive branch, and the Judicial branch. Their respective faculties are to decree laws, to carry them out, and to apply them. For more details on Mexico's institutional configuration, see Eliseo Mendoza Berrueto. *El Presidencialismo Mexicano. Una Tradición ante la Reforma de Estado*. México: El Colegio de la Frontera Norte y Fondo de Cultura Económica, 1996.

² Arnaldo Córdova, "La Concepción del Estado en México y el Presidencialismo" en Pablo González Casanova (coord.), *El Estado en América Latina, Teoría y Práctica*, Universidad de las Naciones Unidas y Siglo Veintiuno Editores, México, 1990. See also Pablo González Casanova, *La Democracia en México*, Ediciones Era, Mexico, 1965.

³ Constitución Política de los Estado Unidos Mexicanos, Editores Mexicanos Unidos, 1999.

One of the areas where this arrangement is still very present is the State's provision of social services, not only because access to these services has been used in the political bargain between the State and organized social groups, but because the provision of these services has required a large bureaucracy. Currently, the largest State bureaucracies are concentrated in the social service agencies such as the IMSS. Not only do they control the largest organized work forces and have mobilization capacity at national level, but they have daily direct contact with a significant portion of the population, particularly the formal work force. Thus, their unions have become key political players with their own vested interests as intermediaries in State-society relations.

The Executive

The Executive branch of power is headed by the President who is elected every six years with no right for re-election. He has the formal prerogative to name the heads of the 16 ministries⁴ and their vice-ministers. The core ministries, that carry outstanding weight in policy decision-making, are those that form the economic cabinet: the Finance Ministry (Secretaría de Hacienda y Crédito Público), the Commerce Ministry (Secretaría de Comercio y Fomento Industrial), the Labor Ministry, the Social Development Ministry, and what was until recently the Office of the Presidency. The now autonomous Central Bank also plays a major role in macro economic policy and the design of programs with a high financial content such as the pension reform.

Policy decision making occurs in the Executive cabinets that are chaired by the President himself. These cabinets are organized by policy areas: the economic cabinet (that meets twice a month), the national security cabinet (that meets monthly), the social policy cabinet (that meets twice a month), the foreign affairs cabinet (that meets monthly), and the agriculture cabinet (that meets every two months). The most important one is the economic cabinet. When policy issues acquire special relevance, the minister responsible for the topic is summoned to present the issue in the economic cabinet—even if the topic is related to the subject area of another cabinet. Such was the case, during the Zedillo administration, of the pension reform, as well as health reform and poverty alleviation, programs that would have otherwise been dealt with at the social policy cabinet.

Policy issues and initiatives may be prepared in any of the ministries and presented by one of the ministers or undersecretaries that may be asked to do so for a particular matter. Cabinets may also request the creation of an interagency group to study a policy issue and/or formulate a policy initiative to be analyzed at the cabinet level.

The Office of the Presidency (later converted into two coordinated sets of presidential advisors) played an important support role as a technical a-political body. The office was also in charge of studying and presenting policy options for consideration by the president and the cabinet meetings. Beginning in mid-1960s, the Office of the Presidency was an attempt to centralize and rationalize policy decision making. Comprized of a small group of presidential advisors, the Office would study and suggest policy guidelines to the president and do follow-up on the ministries' policy making. Although at first it was an informal institutional arrangement that changed names and profile several times, it grew in size and acquired central importance with the arrival of the technocracy in power in the mid 1980s. It offered a flexible space for policy

⁴ The Ministries are: Interior, Foreign Affairs, Finance, Labor, Energy, Agriculture, Social Development, Health, Education, Environment, Comptroller's, Commerce, Agrarian Reform, Defence, Marine and Tourism.

decision making to the technocracy, and was useful to circumvent vested interests in the ministries' bureaucracies.

This organization reached its peak during the consolidation in power of the technocracy in the early 1990s, when specialized cabinets were formally organized and the Office of the Presidency was created by presidential decree. It consisted of a series of technical coordinators each corresponding to a policy area of a specific cabinet. It worked as a policy power house—dictating policy and arbitrating the competition among ministries for influence in policy making and power. The Office of the Presidency was formally dismantled close to the end of the Zedillo administration and substituted by two coordinated sets of presidential advisors, one responsible for internal politics and foreign affairs, and the other responsible for social and economic policy.

The Finance Ministry is the other center of power, particularly since the merging of the Planning Ministry and the Finance Ministry, giving the latter the responsibility of both overseeing the government's policy agenda and determining budget allocations. These ministries had the highest concentration of technically skilled and highly prepared policy makers from the 1960s on. It was from their ranks and those of the Central Bank that the technocratic group emerged and seized power in the 1980s.

Legislative power and its relation with the Executive

Legislative power in Mexico is exercised by the Congress of the Union, which is composed of the Lower House and the Senate. National representatives legislate in the former, and the states' representatives in the latter. Both bodies need to approve a law for it to be legislated.⁵ The legislative body that receives a law initiative in a first instance is called "chamber of origin;" the one it is sent to in a second instance is called "revising chamber." When a law initiative is received by one of the legislative chambers, one or more commissions are appointed to study it. Once the commissions have discussed the initiative, their recommendation is forwarded to the general assembly for final discussion and, possible approval. Finally, the initiative is remitted to the revising chamber in which a similar procedure takes place. At the end of the process, the initiative is sanctioned by both chambers and sent to the Executive, who has the obligation of issuing the law and ordering compliance with it.⁶

The Executive is granted by the Constitution a series of formal attributions with respect to the Legislative power. These powers include the right to veto Congress resolutions;⁷ to submit law initiatives to Congress—which turns the Executive into an important source of new legislation⁸, and the right to choose, with certain limitations, the chamber of Congress to which the initiative will be sent in the first instance.

⁵ The sole exception is the Federal Budget, which only requires the approval of the Lower House.

⁶ If the revising chamber does not agree with the recommendation sent by the chamber of origin, the initiative is returned to the latter with amendments. If the chamber of origin does not accept the amendments, or finds that new ones need to be made, the initiative goes back to the revising chamber. If this chamber does not accept the amendments for a second time, the law initiative is not approved.

⁷ If the president disagrees with a law that has been approved by Congress, he can return the document with his observations to the chamber of origin for further discussion. For the law to be approved, a qualified majority of two thirds of the votes is required. The procedure is repeated in the revising chamber. If approved, the initiative is sent to the Executive, who must then issue it.

⁸ The Executive has been for a long time the main source of new legislation in Mexico, with Congress assuming only a reactive role, rather than a proactive one.

However, the Executive's unbalanced relation with Congress has not only been determined by its formal constitutional attributions. The President in Mexico relies on a series of *extra-constitutional* powers derived from his relation to the ruling party, which, until very recently held an absolute majority in Congress.⁹ These informal attributions, such as the control over the political career of PRI legislators, along with the Congress' weak professional and institutional capacity to formulate and study law initiatives, have made it possible for the Executive to become virtually the sole source of law initiatives. This has also allowed the Executive to transfer the policy decision making and negotiation to other arenas outside public scrutiny, such as the ruling party or the Executive itself.

Since 1988, the Presidency's *extra-constitutional* powers have weakened as a consequence of the slow political liberalization process. However, it was not until 1997, when the PRI lost its majority in the Lower House, that the president lost the power to have his law initiatives approved without effective opposition, and thus legislate practically on his own. From that moment onwards, he has had to negotiate not only with the opposition parties for the approval of his law initiatives, but, for the first time, with his own party's ranks. Political competition has weakened the ruling party's discipline, since the costs of dissension have diminished, and those of voting in favor of unpopular law initiatives, have increased.

Judicial power and its relation with the Executive

Judicial power is vested in the Supreme Court, the tribunals, the district courts of justice, and the Federal Judicial Council. Congress is responsible for sanctioning the procedural law that regulates the judicial apparatus, and the Senate, along with the President, intervenes in the designation of the Supreme Court's members. At the behest of the Executive, the Judiciary underwent a major reform in 1994, following a Constitutional amendment that sought to ameliorate its procedural capacity and restore its autonomy.

The Judicial branch has been the weakest of the three powers of the Union. It faces very serious institutional problems in the administration of justice that are related to the lag in the modernization of its procedural capacity. For instance, prior to the 1994 reform, the Supreme Court's members grew from 7 to a total of 26, making the administration of justice more complex and less unified, and there was no limit on the time taken for the resolution of cases.

Most importantly, through a series of formal and informal rules, the Judiciary's independence had been checked and limited since the definition of its relation with the Executive in the 1917 Constitution. These rules dissolved the Federal Judicial Council, which had been in charge of administering the functions of the Judiciary, and made its budget subject to the approval of the Executive and Congress. Until 1994, the Executive had the power to name and remove the President of the Supreme Court, whose position used to have the same life span as that of the government's administration. A similar situation occurred with the Supreme Court's members, whose nomination had thus become very politicized.

The 1994 reform of the Judiciary sought to restore its independence and de-politicize it through a series of measures. These include the creation of the Federal Judicial Council, the reconfiguration of the Supreme Court (bringing its number back to seven), and the modification of the prerequisites for the nomination of judges and the president of the Supreme Court – none of whom can now be named or removed by the Executive alone. The power to designate the Supreme Court's ministers (including the President of the Supreme Court) was transferred from

⁹ See: J. A. Weldon, "El Crecimiento de los Poderes Metaconstitucionales de Cárdenas y Ávila Camacho. Su Desempeño Legislativo, 1934-1946" en *Diálogo y Debate de la Cultura Política*, Año 1, núm. 1, 1997.

the Executive to the Senate (although the President still presents the candidates for these positions) and they must be approved by a two-thirds majority. Also, as a result of the reform, the Executive's nomination of the General Attorney needs to be ratified by the Senate.¹⁰

2. The corporatist system of interest representation

The Mexican political system that emerged after the ten years of factional infighting that followed the end of the revolution in the 1920s, was organized around a corporatist model.¹¹ State-society relations were structured around the PRI, the ruling party, in which organized groups created or supported by the State, and representing key interests in society, were incorporated in an organic manner. The corporatist system was consolidated in the thirties, during the Cárdenas administration, at the same time, and around, the strong Presidency system—or *presidencialismo*—that was going to characterize the Mexican system the rest of the 20th Century. Cárdenas believed that mass participation in politics should be promoted and managed through representative organizations. As early as his electoral campaign, he promoted the creation of workers' organizations and resorted to them as a political base of support. By the end of his term in office, not only workers and peasants were incorporated through formal organizations, but also the business community.

In 1938, he modified the structure of his party, then called the National Revolutionary Party, which had been founded in 1929 by the most important leaders of the Mexican revolution. He renamed it the Party of the Mexican Revolution and reorganized it as a corporatist organization where three social sectors were assembled: workers, peasants, and the military.

This strategy helped him counterbalance the power of the military political elite who, although not acting in duty, controlled the State. In this new system of representation, the Mexico's Workers Confederation (CTM) was going to play the central role as the most powerful labor organization within the party. The National Peasant Confederation (CNC) assembled the agrarian sector, which was also to play a crucial role in consolidating the State's presence throughout the country.

During the Ávila Camacho administration (1940 - 1946), an umbrella urban social group that gathered small businesses, independent professionals, and other middle to low income groups, was named the popular sector (CNOP), and incorporated into the ruling party as well. Finally, in 1948, President Miguel Alemán (1946 - 1952) reformed the party once again. He disincorporated the military sector thus completing the transition to civil rule, and called the party the Institutional Revolutionary Party (PRI).

With the corporatist inclusion of organized social groups, the ruling party became not only a mechanism of mass control, but the central arena for political negotiation. As an instrument of control, the party collected the demands of its membership, and articulated and filtered them to higher decision making circles. The same channels were used in the opposite direction, when

¹⁰ For more on the 1994 reform of the Judiciary power, see José Vicente Aguinaco Alemán, "La Reforma al Poder Judicial de la Federación 1994 - 1995" in *La Justicia Mexicana: Hacia el Siglo XXI*, UNAM y Senado de la República LVI Legislatura, México, 1997.

¹¹ A corporatist arrangement is "a system of representation of interests in which social groups are organized in a limited number of categories: unique, obligatory, not competitive, hierarchically ordered and functionally differentiated, recognized or authorized (even created) by the State. These categories are granted a deliberate representative monopoly in exchange for accepting certain controls in the selection of their leaders and limiting their demands." Phillippe C. Schmitter (1979).

decision-makers wanted to communicate their lines of action to party members. The competition among the different ideological positions and policy agendas that are pursued by the groups that comprise the party were mediated and settled within the limited and very structured party arena.

In exchange for organized support, these sectors enjoy, up to the present day, privileged access to public goods and services. Other groups with the same needs, but who were not politically organized have been excluded from them. Public goods and services, such as health, education, housing; as well as higher salaries, reach social groups through the organizations that assemble them. So, while in theory social benefits are distributed according to the State's commitment to improving the life conditions of the population, access to them is a reflection of the corporatist organizations' bargaining capacity.

The stability of the Mexican political system thus is built around a series of alliances and tacit agreements that are constantly renewed by the different interest groups. The coalition that is thus formed legitimizes the system and serves as its base of support. Therefore, the logic behind policy decision making and formulation is permeated by the need to maintain the equilibrium within this coalition of support. In considering who gets what and how when defining policy, and in order to maintain the system's stability and to preserve the institutionalized agreements among interest groups, policy makers resort to a combination of concessions and impositions over them.

The rules of the political game materialize in patron-client relations among key groups. These arrangements are established according to the circumstances and the relative political weight of each group. The construction of the corporatist pact is influenced by personal and clique ties and rests on political intermediaries that build up the relationships between social groups and the State. The State establishes the rules of the game. It also functions as an arbiter to maintain the corporatist arrangement's balance and to prevent or resolve conflicts among the different social groups that compete to increase their influence and their access to public goods and services within the policy making process.

From the mid-thirties to the early eighties, the State had enough resources and political will to incorporate mobilized groups into the corporatist pact. But due to the shortage of resources as a result of the early eighties and mid-nineties economic crises, the corporatist pact between the Mexican State and the social sectors has been undermined. The lack of resources has limited the State's capacity to incorporate new politically mobilized sectors. Also, as population growth surpassed the economy's capacity to create jobs, large segments of the population joined the informal economy, and as such, were left out of the corporatist pact. Thus, the State's political returns of maintaining this arrangement diminished considerably, and instead, the need to re-consider State-society relations became clear.

An additional factor that has contributed to weaken the corporatist pact has been the arrival in power during the De la Madrid administration in the mid eighties, of a technocratic group with an ideological stand that opposed the idea of the State as central mediator in society. Interestingly, however, this technocratic group has had to resort to the corporatist arrangement it opposed and undermined, in order to maintain control over social groups in order to pursue its structural adjustment agenda. This explains why the technocracy in power has been careful not to tamper with the corporatist pact in those arenas that were not a priority in their reform agenda, but that instead could be a source of political support. Such was the case, though hardly unique, of the social sector, and particularly social security.

The Actors

The corporatist arrangement in Mexico between the State and society has rested on the inclusion of different social sectors organized around or with very close ties to the PRI. Among

them, three stand out for their economic weight and/or their mobilization capacity: the business community, the labor movement, and government bureaucracies.¹²

The business community is not part of the corporatist structure of the ruling party, nor does it mobilize collectively in support of the system. However, it has represented a base of support for the State in exchange for protected markets, subsidies, and other benefits that were part of the development model used in the 1950s and 1960s, but that persisted until the market liberalization that started in the mid 1980s. Due to its fundamental role in the productive processes and its control over financial resources, the business elite has had personal access to high-level public officials. This has allowed it to directly influence policy making. The formal intermediaries between the government and the business community are the entrepreneurs' chambers of commerce,¹³ but heads of large businesses have personal access to policy makers.

The organized labor movement has functioned, since its incorporation to the ruling party in the mid-thirties, as the fundamental base of political support for the State. Official unions have successfully maintained the exclusive intermediation channel in the relation between the State and labor, obtaining exclusive benefits for its membership and monopolizing the control of key State industries and social services for more than four decades. The oil workers union, the State electricity enterprises unions, the teachers' union, and social security unions are among the largest and strongest in the country.

As with organized labor, the State has established a system of exchange of exclusive goods and services for political support with the low-level bureaucracy. The formal intermediaries between low-level bureaucrats and the government are their unions. Not all bureaucrats belong to State workers' unions. High- and middle-level bureaucrats hold temporary contracts renewable at the discretion of their superiors, and resort to networks of support, known as *camarillas*, to pursue their policy making and/or political careers.

The following diagram presents a general map of the actors involved in public decision making (Diagram 1). Those social actors most relevant to the specific arena of health reform will subsequently be characterized in detail.

¹² Three groups of civil servants may be distinguished within the government bureaucracy: a high-level bureaucracy, a medium-level bureaucracy, and a low-level bureaucracy. Only low-level bureaucrats are organized in corporations that exert collective action in order to gain a presence in the political arena in defence of their interests.

¹³ Most of these business chambers of commerce were not very representative and have served the interests of a privileged group within them.

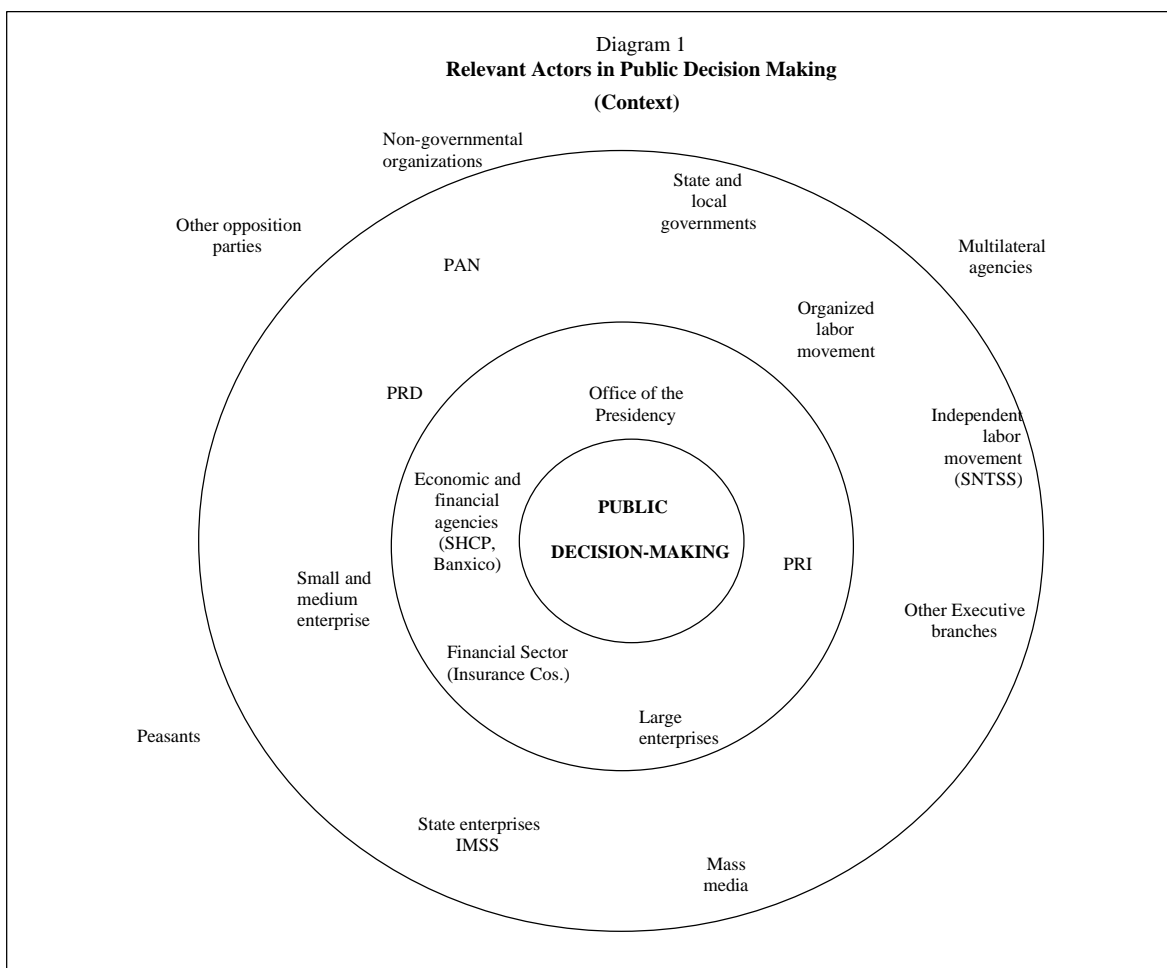

1. The business community

After the end of the 1910 - 1920 revolution that ended a thirty year long dictatorship, and another ten years of factional infighting, the winning factions came to a power sharing agreement and founded Mexico's political system. A new social pact was established to regulate the relations between society, the economy, and the State. In relation to the State, the principles on which this new pact was based included its hegemony as the central promoter of economic development and income distribution; the concentration of power in the Executive; and the non re-election of the President. In relation to the economy, the principles included a model of economic development based on import substitution, industrialization, and the State's intervention in most economic activities. In relation to society, the principles included the recognition of popular groups as legitimate political actors, as long as they were subordinated to the hegemony of a ruling party.

Business was to be the sole exception, in that it was not allowed to have an open political role and be a formal part of this arrangement. However, it was also closely controlled by the State and could channel its demands either through its organizations or through personal contacts. Thus, although not an openly recognized political actor, the private sector constitutes a power group in the political system because the State assigned it a key role in the industrialization process.

From the 1940s to 1970s, the unwritten rule that forbid businessmen to participate openly in politics as a group, was carefully respected, although their individual incorporation into

political parties was accepted. Nonetheless, the government implicitly recognized the business community's right to participate in the formulation of public policy, supporting, if not forcing, the existence of business organizations that worked as arenas for consultation. The political strategies of business in that period were veiled and not institutionalized, but very articulate and with great capacity to press for its interests.¹⁴

During this period, collective action through business chambers was not crucial for employers because they did not detect any serious threats to their interests. The business community refrained from openly criticizing the government because the latter maintained an adequate climate for investments and profit generation. It also exercised control over organized labor and subsidized the private sector. Business organizations that had been formed and strengthened during periods of conflict, languished once the antagonism was over.

During the Echeverría administration (1970-1976), the implicit pact between government and the business community was broken. The main business groups opposed president Echeverría's attempts to further strengthen the hegemony of the bureaucracy and expand the State. The creation of the Business Coordinating Counsel (CCE) in May 1975, marks the peak moment of antagonism between the State and the business community. Through this umbrella organization, employers sought to act in a coordinated manner, and not as isolated pressure groups. The association soon acquired power and still has significant influence in policy making.

The more conservative economic policies followed during the first two years of the López Portillo administration (1976-1982), as well as the increase in oil revenues that followed, contributed to dissipate the conflict between the business community and the government. However, during President López Portillo last two years in office, State-business relations were strained again due to the imminent economic crisis. The tension reached its peak with the President's decision to nationalize all the private banks in September 1982. A major capital flight followed and further complicated the economic crisis. State-business relations reached a bottom low, since businessmen did not feel there were a minimum set of guarantees in State policies and/or certainty to continue productive investment in the country, and decided to become openly politically active (Puga, 1986).

However, the arrival of the technocracy to power and its market liberalization agenda was to nourish strong ties with the business sector that saw its interests favored with deregulation, support for export industries, and protection of the financial sector. For the political feasibility of health sector reform, two events mark this turning point. The most important one is the fact that for the first time, the State relaxed its historical alliance with the organized labor movement, although they did not speak openly about it. Second, probably as a consequence of this, the business community became openly vocal about its preferences in policy making.

A segment of the Mexican business community thus evolved from a passive and apolitical attitude to an active one; ready to formulate policy proposals and participate in policy decision making, as well as to openly support political parties, even against the PRI. While the business sector that was negatively affected by the market liberalization policies of the 1980s and 1990s voiced their opposition to these measures, those groups that benefited from it established more open alliances with the technocratic group of policy makers leading the reforms. The opportunities business had to comment on policy direction on a person-to-person basis expanded, and members of the clear network that included the powerful business organizations

¹⁴ For more on the relation between Business and the State, see Sylvia Maxfield and Ricardo Anzaldúa, (eds.), *Government and Private Sector in Contemporary Mexico*, University of California, San Diego: Center for U.S.-Mexican Studies, 1987.

that had been critical of the former pro-State administrations, now were willing to share information and knowledge with policy makers that showed interest in pursuing reforms. On the other side of the table, this new group of policy makers did not see this exchange as capture and, without fear of losing control over access to decision making, welcomed these approaches.

For the first time, the business community initiated activities to have public policy proposals prepared in private think tanks that it would then present to the Executive for consideration. In most cases, the issues it concentrated on pertained to the economic sphere.

However, in the early 1990s, a group of businessmen financed the Health and Economy project undertaken at the Mexican Health Foundation (FUNSALUD), a private think tank founded and financed by them and international donors. Their idea was to have a serious technical argument that could justify an in-depth reform – or even dismantling – of the Mexican Institute of Social Security. The IMSS, in their view, was an inefficient State agency and one that was rather onerous to them. In the end, the resulting document, lobbied and promoted with their support, did significantly influence the Zedillo administration's health sector reform program. This was in spite of the fact that it fell short of actually proposing the dismantling of IMSS. Instead, they presented a more comprehensive long-term proposal for the entire sector.

2. The labor movement

The legal framework

The corporatist relation between the government and official workers' unions in Mexico rests on a series of laws, among which the following stand out: the 1917 Constitution, the Federal Labor Law of 1931, and the *cardenista* reforms of 1937. Article 123 of the Constitution sets the frame for the negotiations between employers and workers and formalizes the State's role as the arbiter in labor disputes.¹⁵ The Federal Labor Law establishes the right of workers to form labor unions, but limits their potential strength by requiring them to register with the authorities before exercising the right of collective action. The State has made extensive use of this pre-requisite to consolidate the official labor movement and its close relationship with government.¹⁶

From the late forties onwards, and possibly due to the government's need to exercise greater control over the unions that did not belong to the official workers confederations, it was made mandatory to inform the authorities of any change in union leadership. This implied that without governmental recognition, union leaders could not legally carry out their functions. Insofar as unions without recognized leaders were not considered legal, the State could influence the selection of their leaders. Thus, unions in Mexico were created under strong State control, manifest in the government's prerogative to decide on the legality of these labor organizations and influence the selection of their leaders.

As for the low-level State bureaucracy, during his administration in the 1930s, President Cárdenas presented to Congress the Statute for Workers at the Service of the Executive. With this law he intended to regulate the relations between the State and civil servants. From that moment on, the work conditions of governmental bureaucracies were regulated by a special

¹⁵ For more on the State's role in labor conflict, see Arnaldo Córdoba, *La Ideología de la Revolución Mexicana*, Ediciones Era, Mexico, 1970.

¹⁶ For an analysis of the political context in which the Federal labor Law was formulated, see: Lorenzo Meyer, Rafael Segovia y Alejandra Lajous, *Historia de la Revolución Mexicana 1928-1934. Los Inicios de la Institucionalización* XI, México: El Colegio de México, 1981, pp. 237-238.

regime, which granted bureaucrats certain privileges, like work stability, in exchange for restrictions to their collective rights—such as their right to go on strike. In 1938, State workers' unions were congregated in the Federation of State Workers' Unions (FSTSE).¹⁷

Official unionism

The labor movement that has pre-eminence in Mexico due to the number of its affiliates, and its political leverage, is official unionism, which was incorporated into the ruling party (PRI) and the State since 1938. With the inclusion of organized labor in the PRI's corporatist structure, the strategy of exchange of public goods and services for political support was institutionalized.¹⁸ The structure of representation and participation of official unions is vertical and authoritarian. Unions are headed by bureaucracies that function as intermediaries between workers and government, and union leadership tends to back the State's economic and political proposals—and is rewarded accordingly. The State resorts to the control of official labor unions to guarantee its policies' continuity and to preserve political and economic stability.

Although unionized labor represents less than 25% of the economically active population, its political and economic influence has been considerable. This is due to the fact that it is a key actor in the institutional State-society relations, as described above; and because it predominates in every strategic sector of the economy and all government agencies.

Among official labor unions, the CTM stands out for the number of its members and for its political influence.^{19 20} Its relation with the State is representative of the process that official unionism has followed. For many decades it played a significant political role, having the power to assign members to electoral positions in Congress and state governments. It was able to obtain exclusive benefits for its workers and successfully pressed the State to maintain the purchasing power of salaries. However, its power of influence started to decline since the early 1980s, losing ground in the political arena as a reflection of the exhaustion of the corporatist pact.

As the informal sector grew, and independent unions became more vocal, CTM's political role in maintaining the system's stability was diminished, although not abolished. With this decline, its capacity to maintain a privileged position and influence policy making slowly eroded and it became a sounding board for the State's policy agenda – even when this was to the detriment of its membership.

Independent unionism

Independent unions act at the margin of the official labor movement and the corporatist pact. These unions' basic demands are, on the one hand, salary and benefits increases; and on the

¹⁷ For a review of the FSTSE foundation, see: Carlos Sirivent, *La Burocracia, México: Anuies*, 1977, pp. 69-70.

¹⁸ For details on the political bargaining process between the State and the official unions, see Maria Victoria Murillo, Harvard Ph.D Dissertation, 1997.

¹⁹ In 1980, the number of CTM affiliates reached 2 million, and gathered 42% of the Congreso del Trabajo (CT) total number of members. See Camacho, 1980.

²⁰ Other workers' organizations affiliated with the ruling party are: the Revolutionary Confederation of Workers and Peasants (CROC), Mexico's Workers Revolutionary Confederation (CROM), the Revolutionary Labor Confederation (COR), the General Workers' Confederation (CGT), and the FSTSE. ²⁰ One last important official labor organization is the Workers Confederation (CT). This institution was created in 1966 as an umbrella organization for the national pro-government labor confederations.²⁰ Its capacity to coordinate the various labor confederations and to exert collective action in favor of its members has been, however, limited.

other, recognition of their legal status to be able to exercise their right to subscribe to collective labor contracts, which are normally under the control of official unions.

Historically, the independent labor movement's capacity to influence policy making and protect its interests has been weak given its low membership and limited political power.²¹ Its development has been slow and difficult due to the State's control over labor organizations—sanctioned by law, and the government's support—in the form of financial resources and political backing—for official unions.

The 1982 economic crisis represented a turning point in the relations between State and official unions. Since the real value of the minimum wage decreased drastically during the first years of President De la Madrid's term,²² the government tried to compensate organized workers through additional concessions.²³ But soon the worsening of the economic crisis in 1985, forced the government to tighten fiscal expenditure and further structural adjustment, deepening of market liberalization, and the privatization of public enterprises.

The erosion of the corporatist pact between the State and official unions due to these policies, favored formation of new, more belligerent workers' organizations and the strengthening of independent unionism outside the State's control. Due to the Workers Confederation and the CTM's inability to defend their membership's interests, several unions, traditionally linked to them, and through them to the ruling party and to government, considered the need to secede from them and constitute new organizations capable of defending their interests.

Thus a group of discontented unions, led by the Telephone Worker's Union, constituted the Federation of Goods and Services Unions (FESEBES) in 1990.²⁴ The new federation emerged against the opposition of CTM and the CT. The FESEBES presented itself as the prototype of *new unionism*. That is, it was a labor organization willing to accept more flexible work contracts and preoccupied with firms' productivity, but also with the capacity to exercise collective action to defend its own political and economic interests. Thus, the federation's strategy is based on cooperating with the State's reform agenda, which it assessed to be inevitable, in exchange for participating the reform formulation and implementation.

In a further step towards the strengthening of the independent labor movement, in 1995 in the context of a new deep economic crisis, the National Union of Education Workers (SNTE)²⁵

²¹ Sources for the analysis of independent unions are scarce and disperse. Government labor statistics are of little use in establishing the number of these independent organizations and their membership. For more on the independent labor movement see Juan Felipe Leal, "Las Estructuras Sindicales" en *El Obrero Mexicano, Organización y Sindicalismo*, 3, México: Siglo XXI, 1986, pp. 86-88

²² From 1982 to 1988 the minimum salary decreased 48.3% in real terms. Aspe, 1993, pg. 25, cited in Murillo, pg. 153.

²³ De la Madrid's government established price controls on leases, transportation and basic products. It also allowed the participation of the CTM in the distribution of basic products through workers and union controlled enterprises. Additional resources were assigned to the Workers' Bank (Banco Obrero), controlled by labor unions, to establish subsidized stores for workers and to increase the bank's contributions to institutions such as the National Institute for Workers' Housing (INFONAVIT) and the National Fund for Workers' Consumer Goods (FONACOT). Ibid.

²⁴ The FESBES obtained its official registration in 1992. Its membership includes: the Telephone Worker's Union, the Film Workers' Union, the Railroad Worker's Union, the Union of Airplane Stewards, the Electrical Worker's Union and the Airplane Pilots Union. Its first Secretary General was Francisco Hernández Juárez, leader of the Telephone Worker's Union.

²⁵ At the time the largest union in the country and in Latin America.

summoned other workers' organizations to a forum, called *Sindicalismo ante la Nación* (Unionism vis a vis the Nation). The FESEBES soon joined, along with a group of smaller unions which were formally members of the CT, but were not feeling represented and were close to the SNTE and its confrontational tactics. But most significantly, the IMSS union, the SNTSS²⁶ also joined.

The forum triggered coordination among independent unions that did not exist before, and made it feasible for them to organize themselves outside the realm of the CT (Interview, 04/21/99). From then on, the movement came to be recognized as the *foristas* – for their participation in the forum, and in the following two years its members worked on the project of a new labor confederation. This was founded in 1997 with the name of National Workers' Union (UNT),²⁷ and according to its leaders it has a total membership of one and a half million affiliates.²⁸ Among the most powerful members of this new organization were the SNTSS,²⁹ the STRM, the National University Workers' Union, the Union of Airplane Stewards, and the Authentic Labor Front (FAT).³⁰

This new confederation soon established its independence *vis-a-vis* the government and rejected the State's old vertical control over labor organizations. It openly demanded a more active role public policy formulation, and opposed the government's neo-liberal policy agenda as damaging to labor.

This labor confederation has proven its capacity to exercise collective action in defense of its interests.³¹ As opposed to the official labor movement, its strength rests on its credible threat of collective action and the joint participation of several of the strong unions that have now joined it. The official labor movement is trapped in a dilemma between continuing its historical alignment with government, which has proven very effective in the past for its membership, and taking a more radical position in order to protect its interests. Thus, the independent movement has represented a very serious threat to its already dwindling position of political influence. The fierce competition between the two organizations, has had important consequences for the State's capacity to pursue reform.

Their rivalry to become the central interlocutor *vis a vis* the State—with both groups considering various strategic options along the cooperation/confrontation continuum—has played an important role in the politics of IMSS' health reform. It has precluded the formation of a large

²⁶ The second largest union in the country.

²⁷ Not all *foristas* were ready to step out of the CT and to end the corporatist relation with the State. Therefore, they did not join the newly created UNT. One of the unions that decided to stay within official unionism was the SNTE. However, eight of the CT's most important member unions abandoned this official umbrella organization and joined the UNT.

²⁸ Reforma, 1° de mayo de 1999.

²⁹ One of UNT's leaders is Fernando Rocha Larráinzar, leader of the SNTSS.

³⁰ The UNT is not the only independent workers' confederation that appeared in the nineties as a result of the erosion of the corporatist arrangement between the State and the labor sector. The 1st of May Inter-unions Coordination was conformed in March, 1995. This organization assembled a group of unions and popular organizations, such as: the Independent Popular Movement, the Metropolitan Autonomous University Workers' Union and the Popular Front Francisco Villa. According to its leaders, the coordination has 1,000,000 affiliates in 1999.

The Mexican Unions' Front (FSM) was constituted in March, 1998. Among its members, the Electricians' Mexican Union (SME) stands out. It also assembles a group of "democratic fractions" of several national unions. The FSM's strength basically derives from the SME's capacity to exercise collective action. So far, the SME has been able to block the government's initiative to reform the Federal Labor Law and the privatization of the electric sector.

³¹ As was the case of the stewards' strike, in 1998.

labor coalition that would have enhanced labor's influence power over policy. The resistance to the reform of the IMSS was (and is) led by the IMSS union, yet without the cooperation of other independent unions. Although IMSS' reform directly affects their interests, official labor associations made their opposition to this union their highest priority, due to its joining the independent movement, over a more active participation in IMSS reform formulation. This position can also be explained by the fact that workers showed a high degree of dissatisfaction with IMSS services (pensions and health), and thus were not clear about the gains and losses the reform would bring them. Nevertheless, the negative impact on its interests, was clear and immediate for the IMSS union.

3. Government bureaucracy

The state bureaucracy in Mexico can be divided in three levels: high, middle, and low. High-level bureaucrats have a privileged position within the governmental structure. They do not promote their interests through unions or any other type of formal organization, but instead pursue their careers and protect their interests through informal links with other policy makers, by means of vertical and horizontal support networks. As is the case with high-level bureaucrats, mid-level officials seek to promote their interests through bureaucratic factions or *camarillas*. Only low-level public employees join State workers' unions in order to pursue and protect their interests by means of collective action.

The Mexican Social Security Institute (IMSS) is an exception among government agencies in that most of its employees, including high- and mid-level officials, are members of the Institute's workers union. Practically all of the Institute's employees, including doctors,³² are members of the SNTSS. The union's control over most positions, including high-level posts, reduces considerably the margin of maneuver of the IMSS directorate, which is appointed by the President, and significantly increases the union's pressure and collective action resources.

High level bureaucracies and their networks

Given the lack of an institutionalized civil service in Mexico, the change of administrations brings with it a massive renovation of personnel within the public sector – and, in fewer cases, between the public and the private sector. The higher the rank of the bureaucratic level, the higher the degree of circulation. In the lack of the institutional mechanisms for a meritocratic career, civil servants are dependent on the networks they build while in a government positions to ensure the continuity of their careers and a certain degree of job security. The President appoints all cabinet ministers and vice-ministers, but secretaries may have a say in the nomination of some of their close collaborators. Each of these, will in turn name his/her work team, and loyalty and trust will be prioritized over expertise and performance.

The change of administration implies, for high- and mid-level officials, a risk as well as an opportunity to advance within the governmental structure. Since there is a high probability that they will have to abandon their current posts, medium and high-level bureaucrats try to establish networks of relation with higher level officials. These vertical networks of support increase their possibilities of maintaining their posts, or even advancing within the government structure (Grindle, 1977).

³² After the repression of the doctors' movement, in the mid-sixties, their capacity to organize as a pressure group was restricted. The only channel of collective action left for doctors, as IMSS' workers, was the SNTSS.

Unlike low-level bureaucrats, who join state workers' unions in order to seek job security and salary increases through collective action, middle and high-level bureaucrats turn to informal vertical and horizontal networks to promote their interests, as well as to pursue their policy agenda. These networks of relation are called *camarillas*, and are created through time by means of complicated alliance building processes.³³ A high-level official is recognized as the leader of the *camarilla*; mid-level officials are protected and promoted by him/her in return for their services and loyalty. These alliances are based on informal reciprocity rules that, to a point, reproduce patron-client relations (Grindle, 1977). Personal loyalty, and not ideology, is the central element that binds a *camarilla* together.

The bureaucratic competition among *camarillas* determines, more than anything else, who holds the high-level positions in public administration (Camp, 1990); and therefore which policy project is to be implemented. So, the power and level of influence in policy making of a group of policy makers with these characteristics, depends on the networks its members are able to build and consolidate.

The various *camarillas* constantly compete to increase their influence over the decision making process, as well as on the formulation and implementation of public policy. Given that, until recently, the President has had the power to designate his successor, the number and importance of the policy projects each *camarilla* is in control of, is often used as a signaling device that indicates its closeness to the top of the bureaucratic pyramid. And this closeness to top-level decision making may enhance the team's positioning in preparation for the following administration. This explains in part why, as the change of administrations approaches, competition peaks and cohesion around the government's policy agenda falters.

The change of administration leads to a replacement of the dominant *camarilla*, with the new President as leader of this pyramidal conglomerate of networks. Those *camarillas* that lost the competition for power are not necessarily forced out of the public sector. It may happen that the leader of a losing group, who did not reach the Presidency, may be assigned a post in the new administration. Members of a losing *camarilla*, may also be recruited into the winning group due to the networks previously established.

The arrival of the technocracy to power in the mid-1980s is the immediate result of one of these power struggles. As it had been the case throughout Mexico's modern political history, these power struggles were permeated by changes in ideology within the State apparatus, society's perception of the State's performance, and national and international pressure to alter the policy agenda. In lack of party alternation, this closed and very structured competition mechanism away from public scrutiny, has produced significant changes in the State's policy direction and its ideology during the last seventy years. Bureaucratic faction competition has therefore reflected competing ideologies and visions, and has also resulted in changing trends in the pre-eminence of politics over technocratic approaches and *vice-versa*. The technocratic group that arrived to power thus sees itself as purveyor of an "apolitical" approach to policy making based on technical expertise and track record of performance. But, as will be argued, it has resorted to similar bureaucratic strategies to pursue power and maintain it in view of challenging competitors.

³³ For more on the process of building and sustaining bureaucratic networks or *camarillas*, see Cornelius and Craig (1988).

4. Other actors in the political arena

Opposition parties

In spite of PRI's seventy-year predominance, opposition parties from both sides of the ideological spectrum have been part of the political context. However, it is only since the late 1980s, and as a result of an arduous fight for political liberalization and free elections, that these parties have arrived to share power in local and state governments. In 1993, for the first time in Mexico's modern history, the PRI lost its majority in the Lower House, and the opposition played an active role in policy decision making. Given Mexico's lack of experience in democratic political competition, alternation in power and interest representation outside the long standing corporatist arrangement has been a learning process for both the PRI, and the opposition parties.

Of the more than eight opposition parties officially registered, two have coalesced in the major forces opposing the PRI. To the left, the PRD (Partido de la Revolución Democrática) emerged from an internal division of the PRI that resulted from the technocracy's control of the party's machine in the mid 1980s. Led by the son of Lázaro Cárdenas, the President who institutionalized the PRI in the mid-1930s, it joined forces with a large group of left wing political organizations in an effort to win the presidency in 1988. Presidential elections that year were strongly contested and the possibility that the PRD had won them has never been clarified. Ever since, the PRD has carved a niche in the center left that was abandoned by the PRI's neo-liberal program that resulted from the technocracy's take-over. It now governs Mexico City and two states, plus several municipalities. It has played a major role in pressing for the country's democratization and in Congress has voted against the Executive's pro-market liberalization policy initiatives—to no avail.

To the right, the PAN (Partido Acción Nacional), emerged in the late 1930s as a reaction to former president Lázaro Cárdenas' statist policies. It brought together a myriad of civic associations of a liberal ideological stand who resented the rapidly expanding State interventionism. During the following four decades, with few exceptions, the PAN played an opposition role with no clear chances of winning electoral posts in local or state governments—given the State's control over elections—until the 1980s. It thus maintained the role of a minority party in Congress with little chance of influencing policy making, but with the moral obligation to point at the State's and the ruling party's excesses, while maintaining a liberal banner. It nonetheless continued to press for political liberalization and now governs three states, the two cities of greatest importance after Mexico City and several others, along with local governments across the country. Since the PRI's turn to the center right due to the latter's control by the technocracy, it has supported many of the Executive's policy initiatives. However, it has continued to press for clear and free elections and it is now the second leading political force in the country following close behind the PRI. In fact, for the first time in Mexico's modern political history, the PAN has real possibilities of winning the 2000 presidential election.³⁴

Civil society

Since the mid-1960s There have been a number of social movements that demanded more participation in policy decision making and more political freedom—notably the railway workers and the doctors movement that were repressed in the early to mid 1960s, and the student movement which was severely repressed in 1968. Civil society has followed a long an arduous process to gain a space in the political context. During the 1960s and 1970s, those groups that contested the State's authority, particularly left wing movements, were repressed and/or co-

³⁴ This, of course, was written before the results of the last Presidential election were available.

opted by it. Self-help groups and peasant organizations that were not controlled by local PRI politicians (*caciques*), were repressed or denied public services and resources in a carrot and stick political strategy. However, as a result of the continuous economic crisis and the State's exhausted capacity to absorb those groups that demanded access to public services and work opportunities, the urban middle income and lower-middle income groups started to organize themselves in self-help groups and to press the State on several fronts.

The emblematic birth of the civil society movement is the 1985 earthquake in Mexico City in which it is believed that more than 40,000 people lost their lives. Faced with the State's slow reaction to respond to the population's immediate needs, regular citizens went out to the streets and organized themselves to help each other. Since then, civil society has played an active role demanding transparent elections, a stop to mass media censorship, and respect for human rights among other issues. The Zapatista guerrilla movement that emerged in Chiapas in 1994, has also triggered social movements in Mexico and abroad, to demand a more equitable income distribution, while emphasizing the enormous levels of poverty that persist.

RESTRUCTURING THE POLITICAL SYSTEM

The Economic Crisis and the Strengthening of Technocracy

Two phenomena mark the early 1980s in Mexico: the debt crisis and the adoption of the neo-liberal economic model with the arrival of the technocracy to power. These events were determinant in the redefinition of State-society relations and the restructuring of the coalitions that supported the State and benefited from its economic and social policies. The magnitude of the economic crisis undermined the legitimacy of the economic model in force until the early 1980s, and severely damaged the credibility of politicians and policy makers in power who promoted it. Thus, the crisis opened a window of opportunity for a technocratic group of policy makers to seize power, promote structural adjustment, and redefine the role of the State and that of the market.³⁵

1. *Origins of the technocratic group*

The beginning of the *Desarrollo Estabilizador*,³⁶ in the late fifties, coincided with the strengthening within government of the Finance Ministry (SHCP) and the group of technicians who led it.³⁷ The power of the Finance Ministry rested on its control over income sources and budget allocation. Control over the budget allowed the Finance Ministry to influence policy making in the rest of the government agencies and supervise the implementation of programs. Furthermore, until the mid-seventies, public administration was based on defining the budget, and not planning; and therefore, the strongest ministry was the Ministry of Finance (Bailey, 1980).

³⁵ For details on the take over of the technocratic team, and the transition from a closed economy model to an open economy one, see Grindle (1996).

³⁶ During the *Desarrollo Estabilizador* (1958-70), an economic strategy of industrialization through import substitution -promotion of national industry and production for the domestic market was implemented in Mexico. Antonio Ortíz Mena, Finance Minister from 1958 to 1970 and Rodrigo Gomez, Bank of Mexico Director from 1952 to 1979, formulated and implemented economic policy during the *Desarrollo Estabilizador* period.

³⁷ The presence of a group of technicians within government can be traced to 1821, when the Finance Bureau was established. In 1861 this government agency was given the name with which it is known to date; that is, Finance and Public Credit Ministry (SHCP).

During the Lopez Mateos administration (1958 - 1964), a half-hearted attempt was made to concentrate planning functions in the Ministry of the Presidency. The Ministry of the Presidency was assigned the task of developing national plans and approving expenditures and investments.³⁸ However, this agency was unable to function as the main planning agency, since the private sector opposed centralized planning as an unequivocal sign of further State intervention in the economy. Also, there was no imminent crisis or unsatisfactory economic performance to justify a significant reform in public administration led by the president. So, the economic situation that prevailed during the *Desarrollo Estabilizador* reinforced the Finance Ministry's position.

An important characteristic of the *Desarrollo Estabilizador* period was the consensus among policy makers regarding economic and social policies. This consensus was a reflection of the ideological and programmatic homogeneity among cabinet members. Regarding economic policy, the joint proposals of the Finance Ministry and the Bank of Mexico (the central bank) prevailed. The technicians in these agencies worked around a clear policy agenda: maintaining high growth rates; preserving the equilibrium of the balance of payments; limiting external debt; controlling inflation; increasing internal savings, augmenting private investment levels; and preserving a stable exchange rate (Benett and Sharpe, 1984).

The legal and institutional attributes of the SHCP were reinforced by informal and political factors. Along with the Bank of Mexico, this Ministry recruited the best-prepared economists in Mexico and had the lowest personnel rotation rate (Sirvient, 1975). Its closeness to the Presidency and its technical capacity facilitated its leading role in policy making and in the bureaucratic political competition among government agencies.

2. The Keynesian Years

The 1968 student movement was a turning point in Mexico's State-society relations in recent history—one in which society began to question the State's tutelage, as well as its performance. The political mobilization of the middle class asking for political liberalization, participation in policy decision making, and jobs for the emerging professional groups, marked the exhaustion of the prevailing economic model (*Desarrollo Estabilizador*). When President Luis Echeverría took office in 1970, the consensus around this economic model, which had been in force since the early fifties, was faltering. Also, the State—and President Echeverría himself, since he was the interior minister at the moment of the students' repression—faced its most important legitimacy crisis since its establishment in the 1920s.

President Echeverría considered that this model's central weakness was its incapacity to promote income redistribution and to include a larger number of social groups in the economic development process. Thus, in an attempt to rebuild the strained relations between the State and society, and the objective of pursuing a more inclusive model—at least in form, he endorsed an economic model that was called *Desarrollo Compartido* (shared development). This economic model saw the State as the instrument for income distribution and advocated its participation in the economy, as well as in the definition of the economic and the social spheres.

The President identified policy makers at the Finance Ministry and Bank of Mexico as those responsible for the conservative and exclusive economic policy that had generated the legitimacy crisis. He thus opted to supervise in person the economy and public finances. The liberal economists in these core agencies lost much of their power and influence; and, as they did, a new

³⁸ See: Mexico, Secretaría de la Presidencia, "Ley de Secretarías y Departamentos de Estado", *Manual de Organizaciones del Gobierno Federal*, Mexico: 1976, pp. 65-79.

group of policy makers consolidated power with a nationalist-populist policy agenda.³⁹ This *camarilla* promoted a *Keynesian* economic policy that prioritized income distribution over macro economic performance and enhanced the role of the State as the central instrument for growth promotion and redistribution. These efforts were to be implemented through state enterprises and public spending.

During the López Portillo administration (1976-1982), the two opposing political and economic trends persisted. The *liberal* group still concentrated in the Ministry of Finance, while the *statist* group centered around the Planning Ministry (SPP), which was created in 1976 as part of the reorganization of the federal government.⁴⁰ The competition between these two groups of policy makers and their opposing policy agendas was to be institutionalized in the permanent rivalry between these two ministries until the latter was dismantled—and its activities re-taken by the Ministry of Finance—in the late 1980s.

The ideological principles and economic policy proposals of the predominant groups in SHCP and SPP were in constant opposition. High-level officials at the Programming Ministry argued that the economic stagnation and inflation that affected the country were the result of structural unbalances and bottlenecks that should be solved through greater State intervention in economy.⁴¹ The economists at the Finance Ministry believed that Mexico should implement the more conservative and less *statist* economic policies agreed upon with the International Monetary Fund. This was consistent with the Ministry of Finance's historic conservative position, which concentrated in keeping inflation down to avoid the market distortions it caused. The Bank of Mexico and other national and international banks endorsed SHCP's posture.

The rivalry between these two core ministries with opposing economic models, reached unprecedented levels in which the President was finding it difficult to arbitrate (Bailey, 1980). When the preparation of the 1978 budget reached a gridlock due to it, Tello, the Planning Minister, and Moctezuma, the Finance Minister, were both asked to resign.

The tension between the liberal and the *keynesian* economic models was to continue and President López Portillo forced a political stalemate between both groups. However, the significant increase in oil revenues between 1979 and 1980, discouraged the President from the need to maintain a conservative fiscal policy, and tilted his preference towards income redistribution via State intervention. The liberal economists of the Finance Ministry and the Central Bank lost the battle in favor of the *keynesian* economists of the Planning Ministry, and tried unsuccessfully to control the public deficit.

³⁹ This group's basic economic goal was to promote income redistribution. The roots of this *radical* or *national-populist* group may be traced to the designation of Horacio Flores Peña as National Patrimony Minister in 1970. Jose Andres de Oteyza and Fernando Rafful, among others, belonged to Flores de la Peña's team.

⁴⁰ The Planning Ministry (SPP) was constituted in 1976, as a result of the reorganization of the Federal Government. The new Organic Law of Federal Administration conferred on the SPP the functions of planning, budgeting, and supervising. This tasks had previously been the responsibility of the Ministry of Finance, the Ministry of Patrimony, and the Presidency, respectively.

⁴¹ Greater State intervention in the economy implied a more active role for public enterprises in the production of goods and services. Those officials who supported this economic proposal were concentrated on Lopez Portillos' term in the SPP, and the Ministry of Patrimony and Industrial Promotion (SEPAFIN). An analysis of the technical arguments of the *national-populist* economists may be found in: Horacio Flores de la Peña, *Teoría y Práctica del Desarrollo*, Mexico: Fondo de Cultura Económica, 1976.

The deterioration of the economic conditions that followed in 1981, increased again the tension between the officials in the Finance Ministry and those in the SPP. While SHCP and Bank of Mexico pressed the president to implement austerity measures and carry out a considerable devaluation of the peso, SPP kept on backing spending measures and a lower level of devaluation of the currency.

In March 1982, the power struggle within the cabinet became once again untenable, and the worsening of the economy pressed President López Portillo to ask the Finance Minister and the Bank of Mexico director to hand in their resignations, and substitute them with policy makers from the rival liberal team. At the suggestion of PRI's Presidential candidate, Miguel de la Madrid, Jesús Silva Herzog was appointed Secretary of Finance and Miguel Mancera, Director of the Bank of Mexico. However, the President's leniency towards the liberal or monetarist group proved to be half-hearted. Three months before the end of his administration, he abruptly took the decision to nationalize the banking system, which implied the triumph of the statist faction and triggered the worst economic crisis of the decade.

3. *The arrival of technocracy*⁴²

In 1982, when President De la Madrid took office, the country was immersed in a profound economic crisis. While the origins of the crisis were domestic, its magnitude was increased by the world-wide economic recession that had been unleashed in the early eighties, and the rise in real interest rates; as well as the decrease in international oil prices and a tightening of international credit markets. The pressure of the external debt over Mexico's economy grew to unprecedented levels. In response to this situation, De la Madrid's administration implemented what was called the Immediate Program for Economic Reorganization (PIRE) and it formulated a new long-term development strategy.

Short-term policy concentrated on controlling inflation and the public deficit, while the structural adjustment agenda focused on increasing the efficiency of the productive structure through market liberalization and export diversification, and promoting the downsizing and decentralization of the public sector.

The general perception in the country—and abroad— was that the world economy, and the challenges of the Mexican economy had grown too complex and required specialized expertise to solve them. Furthermore, the immediate need to reschedule debt payments with Mexico's international creditors, enhanced the role of the technical policy makers. While until the crisis they had had an advisory role, and politicians were in charge of direct negotiations, this situation required them to play both roles, and the liberal economists were the only ones that shared the ideology of the creditors. Therefore, they enjoyed a certain degree of credibility.

Thus, the discredit of the outgoing administration and the perceived need to renovate the top-level decision makers in order to face the new challenges, opened a window of opportunity for the arrival in power of a new breed of policy makers. These new policy makers, whose careers had been made in the technical ranks of the financial sectors of government, and not on the party

⁴² Miguel Angel Centeno (1994) defines a technocrat as a person who combines the educational credentials of the technician with the maneuvering skills of a politician. Technocrats have a political agenda of their own; technicians do not. This definition coincides with that of Jorge Domínguez (1994), for whom a technopol is a technically trained individual with political knowledge, who has occupied key positions during critical change periods.

lines and electoral positions, came to be known as technocrats.⁴³ President De la Madrid empowered this group of policy makers, who were to lead the implementation of the economic restructuring and adjustment programs.

The increase in power and influence of the technocratic group corresponded to a decrease in strength of traditional PRI politicians and union leaders, and the displacement of most *keynesian* economists from high-level posts. It is possible that these groups did not perceive the arrival of the technocratic group as a threat to their hold to power, and in fact welcomed it, since they were aware that the economic crisis was of such magnitude that it was putting at risk the political equilibrium that had maintained them in power. This meant that the technocratic group found very little organized resistance, and instead, implemented an aggressive political maneuvering that would expand their scope of influence beyond the financial government sectors, and seize political control.

The impact of this power rearrangement within the State was clearly reflected in public policy, which since then, has concentrated on conservative macroeconomic management as its main priority. The further deterioration of economic conditions in 1985, due to a new drop in oil prices, led the De la Madrid administration to deepen its structural adjustment program, accelerating the process of market liberalization and the privatization of public enterprises.

The radicalization of the structural adjustment policy agenda also facilitated the consolidation in power of the most orthodox faction of the technocratic group led by then Planning minister Carlos Salinas de Gortari, whose open confrontation with Finance minister Jesus Silva Herzog in 1986, led to the resignation of the latter.

While by early 1987 the economic turbulence of 1985 and 1986 had been controlled, a new global economic crisis in that same year was to have a negative impact in the Mexican economy. The world's most important financial markets saw their price indexes drop abruptly, pulling the Mexican market with them. A month later, the value of the peso dropped more than 40% in just one day; and as a consequence, inflation increased considerably. In response to the new crisis the government, through its Planning Ministry, put together an economic pact—the Economic Solidary Pact (PSE)—directed at controlling inflation, that was to be signed by all the key economic actors in the country.

In this new economic pact, labor leaders agreed to restrain their petitions for salary increases; business representatives agreed to support commercial liberalization and made a commitment to limit profit margins and to raise productivity. The government, for its part, pledged to restrain expenses and to reduce the size of the public sector. A structural adjustment project of such magnitude went beyond a short-term response to the economic crisis, and instituted a long-term structural adjustment agenda that assumed, as a key component, the continuity in power of the technocratic group that was leading it.

By the end of 1997, President De la Madrid had already designated Carlos Salinas as his successor, and in order to ensure continuity during the change of administrations, he appointed several members of the latter's team in key positions in government.⁴⁴ So, even before Carlos Salinas became President, he already had in place a wide network of allies in several government

⁴³ Miguel Angel Centeno argues that a technician is an economist, engineer, scientist, or doctor who restricts his scope of action to that of his professional expertise. A technocrat, on the contrary, uses his technical knowledge to accede to positions of political control. Miguel Angel Centeno, pp. 105-106.

⁴⁴ When Salinas de Gortari resigned as Planning Minister to begin his electoral campaign, he was succeeded by Pedro Aspe, a key member of his technocratic group, who was to become his Finance Minister.

agencies, such as: the Finance Ministry, the Bank of Mexico, SECOFI, SEDUE, and the State Ministry, that were to keep their posts—or very similar ones—at the moment of change of administrations (Centeno, 1994).

4. *Carlos Salinas and the consolidation of technocracy in power*

The 1988 – 1994 Salinas de Gortari administration marked the consolidation in power of the technocracy. President Salinas' cabinet was even more homogeneous than President De la Madrid's, and represented a closed and cohesive elite, with roots in the Ministries of Finance and Planning. This economic team had some of its members migrate to other government agencies, thus monopolising policy-making in the key sectors it wanted to reform. Also, in a key political maneuver, in addition to appointing this compact group of technocrats to key posts in the economic agencies, President Salinas designated traditional politicians, like Fernando Gutiérrez Barrios, to direct the political control agencies, such as the Ministry of the Interior. As heads of the peripheral agencies, which were not critical for his government's agenda, Salinas appointed members of social groups considered relevant to preserve his coalition of political support. That was the case of Jesús Kumate, a military doctor, who enjoyed the support of right wing conservative groups, and was designated Health Secretary.

The key members of Carlos Salinas' cabinet were Finance Minister, Pedro Aspe Armella (PhD in Economics from MIT, 1978); Commerce Minister, Jaime Serra Puche (PhD in Economics from Yale University, 1979); Planning Minister, Ernesto Zedillo Ponce de León⁴⁵ (PhD in Economics from Yale University, 1978); NAFTA negotiator, Herminio Blanco Mendoza (PhD in Economics from the University of Chicago, 1978); and the President's chief of staff, José Córdoba (post-graduate studies in the Sorbone and Stanford University). A third of the cabinet members had worked at the Finance Ministry, and half of the cabinet had worked at the Planning Ministry before reaching cabinet positions.

This technocratic team shared a common neo-liberal ideology and a project to rebuild the nation. They supported the integration of the Mexican economy into world markets and considered it important to exploit Mexico's comparative advantages, such as cheap labor and the proximity to the United States, to boost economic growth. One of their basic economic goals was to control inflation rates, not only for the adequate functioning of the economy, but because they felt it had a regressive effect in income distribution. The team was also against State intervention in the economy and favored fiscal balance through moderate salary increases (Centeno, 1994).

The ideological and programmatic cohesion within the group of decision-makers was determinant for the successful implementation of public policies that reshaped the Mexican State and its relation with the economy and society. The dismantling of the Planning Ministry in 1992 returned the planning functions to the Finance Ministry reflecting at the institutional level the concentration of decision making in this group.

During the Salinas administration almost all of the public firms that were not defined as strategic in the Mexican Constitution, were privatized. Such was the case of airlines, steel mills, mines, a part of the petrochemical industry, and the telephone company. The banks, which had been put under State control in 1982, were put back in private hands.⁴⁶ Some of the peripheral activities that were carried out within State agencies that were to remain public, were also contracted out to the private sector. In the case of IMSS, cleaning and garbage collection was

⁴⁵ With the disappearance of SPP in 1992, Ernesto Zedillo was appointed Public Education Minister

⁴⁶ Some duties in several public agencies in charge of providing social services were also privatized. Such is the case of IMSS, where part of the cleaning and garbage collection services were privatized.

contracted to private services.

Opposition to privatization was headed by the unions of the enterprises that were being put on sale. The left wing opposition parties that endorsed a nationalist, State-oriented agenda, also opposed the privatization programs. The bureaucracy in the Ministry of Energy (SEMIP), who had been in charge of controlling the majority of the public enterprises put to sale, also opposed privatization.

Trade barriers were lowered and preference was given to lower consumption costs through foreign competition, instead of subsidizing producers and certain products as had been the case in the closed economy model. Mexico's formerly protected private sector was forced into efficiency and quality—or bankruptcy—by the sudden saturation of domestic markets with foreign products. These reforms coalesced in the signing of the NAFTA agreement with the US and Canada. This not only was aimed at market liberalization, but at ensuring that changes in that direction would not be reversed, as it could be the case if it were only based on domestic policy.

Among the major policy reforms, the reform of Article 27 of the Constitution, in which collective ownership controlled by the State was replaced with private ownership by individuals stands out. Work contracts were given certain flexibility; and the partial privatization of the pensions system was implemented.

On the political arena, the technocratic team in power sought to challenge and dismantle the corporatist structure around which the political system had been organized since the 1930s. The State and economic reforms seriously altered the mechanisms and resources of exchange between organized social groups affiliated to the PRI and the State. There was a serious attempt on the part of the Salinas administration to re-establish State-society relations by replacing the previously relevant organized groups, such as workers' unions and the bureaucracy, with new groups that had formerly been excluded. These new groups were getting organized under the auspices of the government's new poverty alleviation and development programs.

However, economic reforms failed to provide tangible benefits for the majority of the population. Instead, the costs of structural adjustment were being felt by the majority, while there was still much to recover from the 1980s economic crises. Politically mobilized groups, such as the unions of the public enterprises being dismantled or privatized, and the owners of private enterprises who were facing bankruptcy due to market liberalization, were being particularly hard hit and unwilling to support the technocratic reform initiatives. In face of this scenario, and needing to consolidate structural reform through economic pacts signed by the labor organizations and the production industry, the technocrats balked in their political agenda. In the end they resorted to the old corporatist apparatus and its leaders to ensure the reform's continuity and to hold on to power.

5. Technocracy delimited: the 1994 crisis

By the mid-nineties, the impact of the economic crises and the structural adjustment measures that followed, had exerted great pressure over the political system. With very few exceptions, the majority of the population, regardless of income level, had borne the costs—albeit unevenly—and there were no visible positive results after years of budget tightening. This was particularly true in the case of the politically organized groups that had been the core of State-society relations for decades, such as official unions. They were perceiving a dramatic erosion of their purchasing power and the exclusive benefits they had been accustomed to.

Therefore, at the end of Carlos Salinas' administration the need to reconstruct the political tissue and to reconcile the affected groups was evident. The consolidation of the economic reforms and the continuity of the economic model being used, remained the main priority for the technocratic team. But, interestingly, this now depended on rebuilding the bridges with the old political guard. With the designation of Luis Donaldo Colosio as his successor, it seems as if Carlos Salinas intended to achieve both goals at the same time.

Insofar as Colosio was perceived as a politician more than as a technocrat, he would be able to negotiate with those groups who had opposed the technocratic reforms. At the same time, the technocracy did not consider him as a threat to economic reforms or to the consolidation of structural adjustment.

The 1994 political crisis, resulting from the assassinations of Colosio and the PRI's General Secretary, Francisco Ruíz Massieu, thwarted Salinas' strategy. To prevent the accession to power of a group that could have been motivated to reverse the technocratic reforms, after Colosio's death, Carlos Salinas was forced to designate Ernesto Zedillo, a technocrat with no political credentials, to succeed him.⁴⁷

The December 1994 economic crisis, just a few weeks after President Zedillo took office, further complicated the scenario for the technocratic group in power. The impact of the new crisis on the economy proved that it was still very vulnerable, in spite of structural adjustment. To restore the equilibrium of public finances, the Zedillo administration was forced to increase taxes. During the first semester of 1995, after a politically wearing process, a 50 per cent increase in the Value Added Tax (IVA) rate was approved in Congress.

This initiative, along with the IMSS reform approved in December of the same year, were going to be the only two major reforms with an immediate impact on several social groups, that were going to be approved during the Zedillo administration.⁴⁸ Legislators, both from opposition parties and from the PRI, were growing increasingly concerned about having to share the responsibility—and to pay the political price—of approving unpopular measures in view of growing social discontent. In fact, the political cost of the initiatives' approval was so great, that the Executive's capacity to promote other reform proposals was severely limited.

Faced with very little political capital to introduce major reforms and with the need to tighten the budget once again in order to limit the damage of the economic crisis; and in the context of other major economic crisis in other regions of the world, the Zedillo administration opted for minimizing its reform agenda in order to concentrate on stabilizing the economy.

As a result of the new economic crisis and the discrediting of the technocratic group in power, opposition parties grew stronger. In the 1997 mid-term elections, the ruling party lost, for the first time in Mexico's modern history, the majority in the Lower House. As a result, the speed and scope of the Executive's reform agenda was reduced even further. This change in the balance of political forces in Mexico, was reflected in the implementation of the policy agenda.

⁴⁷ At the end of 1994, within a context of political and economic crisis, the technocratic team's cohesion weakened. Although Carlos Salinas had been the group's leader since 1985, he had to leave the country after the December crisis and the members of his technocratic group had to cut ties with him. Pedro Aspe, who had been crucial in the structural adjustment process, retired from government. Finally, Jaime Serra was forced to resign after the "December error" and the consequent economic crisis.

⁴⁸ The only other major reform that was approved was that of the Judiciary Branch, approved in December 1994, and discussed in a previous section.

During the remaining five years of government, the Zedillo administration has been reactive, rather than proactive, regarding the implementation of public policies. This was to have a clear impact on the health reform process.

The Outcome

The economic crises of the 1980s and 1990s, as well as the neo-liberal economic model that was implemented by the technocratic economic team in power, undermined the corporatist pact that had been at the center of State-society relations since the late 1920s. The erosion of the corporatist pact was reflected in a series of political events, such as PRI's fragmentation, the weakening of its electoral hegemony as ruling party and, as a consequence, the activation—albeit slowly—of the democratic mechanism of checks and balances between the Legislative and the Executive powers.

Since its founding in 1929 the ruling party's main function has been to absorb and process the demands of the heterogeneous politically mobilized groups. Its complete control of power left no other venues for effective political participation. Also, its capacity to assimilate and arbitrate different ideological and programmatic postures, and to sway in the ideological spectrum along the lines of national and international trends, reduced the incentives to break apart from it, and oppose it from a different organization. Instead, potential leaders who disagreed with the leadership's political and policy agendas, had the incentives to stay and fight their way up the political system from within. This was further reinforced by the coercive mechanisms party leaders resorted to, in order to ensure party discipline. As a result, very few times has the ruling party been subject to important secessions of dissident factions. As a matter of fact, from the 1950s to the mid 1980s, no dissident movement had coalesced within the ruling party. It took almost forty years, within a context of economic crisis, for an internal dissident group to consolidate.

In the mid 1980s, faced with the growing hold of the technocratic group on the party machine, the nationalist faction within the ruling party saw its power diminished, its capacity to influence decision making threatened, and its chances of gaining power limited. The informal institutional rules by which the elite had rotated power among different factions were no longer working. For these reasons, a part of the party's nationalist wing formed a dissident group and sought to battle for the party's control. This group, called *Corriente Democrática*, opposed the party's leadership and the government's economic and political reform agenda.⁴⁹

The *Corriente Democrática* assembled members of the center-left PRI factions.⁵⁰ Nationalist politicians⁵¹ and *keynesian* economists⁵² joined together to confront the neo-liberal economic policies of the technocratic group in power, and to propose alternative economic measures. Paradoxically, to confront PRI's current technocratic leadership, this group of high ranking party leaders used the party's original ideological postulates; the ones that had nurtured the party's discourse for half a century. That is, a nationalist, pro-State ideological position that centered around social justice.⁵³ The *Corriente Democrática* pointed its finger at the right wing neo-liberal

⁴⁹ See: Uno Más Uno, August 14, 1986, pg. 7: "A pro-democratic fraction has organized within PRI".

⁵⁰ The *Corriente's* ideological posture is stated in its "Work Document # 1". See: La Jornada, October 2, 1986, pg. 1.

⁵¹ Such as Cuauthémoc Cárdenas and Porfirio Muñoz Ledo.

⁵² Ifigenia Martínez and Carlos Tello are two *keynesian* economists who joined the *Corriente Democrática*.

⁵³ For PRI ideology, see Brandenburg (1964).

agenda of the technocratic group that was in control of the party, and confronted the party's ranks with the disjuncture between the government's policy agenda and the ideals the party defended in its statutes.

On June 22, 1986 party leaders announced that Cuauhtémoc Cárdenas, son of the founder of PRI, Lázaro Cárdenas, and Porfirio Muñoz Ledo, former PRI President, leaders of *Corriente Democrática*, had been expelled from the PRI. Aside from ideological differences, this rupture also was the result of the fact that the technocracy had broken the unwritten rules of elite circulation, whereby no single faction would hold on to power – the Presidency – more than six consecutive years.

The *Corriente Democrática* immediately became a critical mass around which a political coalition of center-left movements and small parties was going to be formed. And, for the first time, PRI's hegemony, and indeed the single party political system was confronted by an heterogeneous coalition of former PRI members, non-governmental organizations, former guerrilla groups and left wing parties. After the 1988 presidential elections, this new political organization, which was to become the *Partido de la Revolución Democrática* (PRD), became the second largest political force in the country.

Thus, the July 1988 presidential elections mark the beginning of the democratic opening in Mexico. PRI's poor results, and its meager and very contested victory over the then Frente Democrático Nacional (now PRD), could be traced back to the secession of the *Corriente Democrática* from PRI's ranks. The results also reflected the general discontent due to the negative effects of the economic crises, and the unpopular structural adjustment measures. The electorate demanded a change on the ideological stand of the State's policy agenda, and given that the PRI—for the first time—was unable, or unwilling to respond to this mandate, a significant number of voters opted for PRD's nationalist and pro-State platform. The erosion of the corporatist pact had also taken an important toll on the party machine and its capacity to produce massive voting in PRI's favor.

This was further aggravated by part of the PRI elite's rejection of the designation of Carlos Salinas de Gortari as presidential candidate. The selection of Salinas represented the consolidation of the neo-liberal technocracy hold of the party's leadership, and its continuity in power for another six years. This represented the continuation, for another term, of the liberal policies that had so greatly affected the interests of traditional politicians, *keynesian* policy makers, union leaders, mid- and low-level bureaucrats and other corporatist groups.⁵⁴

The ruling party's presidential candidate won the 1988 elections with little more than 50 percent of the votes amidst serious allegations of fraud.⁵⁵ This was the turning point in Mexico's recent history of a single hegemonic party.⁵⁶ The center-left PRD (then called FDN) suddenly

⁵⁴ A few weeks after Salinas was selected as PRI candidate to the Presidency, several CTM leaders questioned whether their unions should support the official candidate in the forthcoming election. Joaquín Hernández Galicia, *La Quina*, who at that moment was the leader of the Oil Workers' Union, openly opposed the Salinas candidacy. See: *La Jornada*, October 5, 1987, pg. 6; October 12, 1987, pg. 1, October 16, 1987, pg. 7; *Uno Más Uno*, October 5, 1987, pg. 5.

⁵⁵ The allegations of fraud in the 1988 presidential elections were never proven, nor denied, but irregularities were of such magnitude that they became the most serious blow to the legitimacy of the political system and its capacity to function as a formal democracy.

⁵⁶ On July 13, 1988, the Federal Electoral Committee announced the results of the election: the PRI candidate, Carlos Salinas, had won with 50.36% of the votes; Cuauhtémoc Cardenas (FDN) had obtained 31.12 % of the votes and Manuel Clouthier (PAN) 17.07 %. Up to that moment, the lowest percentage the PRI had obtained in a presidential election was 70%, when Miguel de la Madrid was elected president in 1982.

became the second political force in the country. For the first time in Mexico's contemporary history, an opposition candidate, Cuauhtémoc Cárdenas, obtained close to one third of the votes and won by majority in several important entities, including Mexico City, which was to have its first opposition mayor in the following elections.

The erosion of the ruling party's mechanisms of control was evident not only in its unfavorable electoral results. The controversy around the legitimacy of the electoral process, and thus on whether or not to certify Carlos Salinas' victory, that followed in Congress, was also the stark beginning of a more active legislative branch and its slow activation as a counter-balance *vis a vis* the Executive. President Salinas' victory was to be finally certified in Congress without the vote of a single opposition legislator.

Although many of the system's authoritarian features still remain, since the 1988 election opposition parties have gained political strength and electoral presence. In the nineties, opposition parties have consolidated as real a government alternative at both state and municipal levels.⁵⁷

The composition of interest representation in Congress has also changed dramatically since 1988, and the approval of many of the structural adjustment initiatives promoted by the Executive ever since, have had to have the support of opposition legislators, particularly that of right-wing PAN. In 1997, for the first time in modern history, the PRI lost its absolute majority in the Lower House. As a consequence, the chances of having the Executive's policy initiatives approved have been further reduced. The Executive has had to increase its lobbying efforts both with opposition parties, and notably, with its own party ranks in order to have its initiatives approved. This has reduced the Executive's space for maneuver in pursuing policy reform on several fronts—as was the case of health reform—since Congress has been slowly becoming an important veto point.

⁵⁷ At the moment, the National Action Party governs several states including Queretaro, Guanajuato, and Baja California. The Party of the Democratic Revolution governs the Federal District and Zacatecas.

II. POLICY PROCESS

This chapter describes the context within which the health reform was started, the problems of the social security system that the reform finally addressed, and the resulting reform objectives. It also analyzes the different stages of the reform process that are still very much underway. The characteristics of the actors involved, as well as their strategies in the political battle to gain influence over the health reform process are also discussed.

The chapter is divided in five sections. The first one presents the background of the health system in Mexico and analyzes it in the light of the political economy context described in the previous chapter. The remainder of the chapter is organized in the sequential order of a policy process: problem definition and reform formulation, reform legislation, and reform implementation. The final remarks present the key policy nodes and the interaction of the actors involved in the process.

BACKGROUND

The health system's institutional configuration reflects the corporatist arrangement described in the last section, insofar as the provision of health services is perceived as an instrument for political exchange between the State and society. It has been argued that, in Mexico's public provision of social services—with health care being a central feature—politics determine who obtains what, when, and how (Ward, 1994). The capacity of different groups to obtain more and better health services depends on their income, their occupations, positions within the social strata, and, notably, their capacity for political organization, when they resort to the public sector's agencies. Health and social security services are focused primarily on the urban formal workers that are members of the official labor confederations, and other strategic groups such as oil workers, the army and navy, and the State bureaucracy. Non-mobilized groups working in the informal economy, particularly those in the rural sector, have access to second-rate public health services and in remote areas, to no services at all (Funsalud, 1994).

The present health system was organized as such in the early 1940s, with the founding of the Ministry of Health (SSA) and the Mexican Social Security Institute (IMSS).⁵⁸ These agencies were established as part of the government's institution-building process around clear political and economic priorities. It was during that decade that the Mexican political system was consolidated in its present form.

Following a statist model of economic and social development, the role of the State as provider of health services was reaffirmed. The Health Ministry was created by the fusion of the Welfare Ministry and the Health Department, providing for the expansion of medical care coverage to the sectors of the population that did not have formal employment. The enactment of the Social Security Law in January, 1943, and the founding that same year of the IMSS,

⁵⁸ The precedent for the IMSS can be found in the rural medical services of the time that catered to rural cooperatives, insofar as the system of pre-paid services served as a reference to what would become the IMSS tripartite regime. Rural workers, organized in cooperatives, would pay an annual fee corresponding to a fraction of the cost of rural health clinics, thereby becoming entitled to medical and sanitary services, while the State financed the rest. See Gonzalez Rossetti et al., 1994.

instituted the mechanism that would regulate and supply social security services to organized social groups with a formal employment that played a key role in the State's political and economic strategies. Thus, since the forties, there has been a system of public health care services provided by the MOH and destined for the general population, and a parallel system with exclusive services for formal workers organized around the social security system financed by a tripartite contribution from the government, the employers, and the employees.

The relevance of IMSS as a centerpiece of the corporatist arrangement with politically organized social groups was clear from the start. *Per capita* government resource allocations favored disproportionately IMSS affiliates until the mid-1990s. Governments turned to IMSS to maintain and expand coverage, and also protected its financial stability in times of economic crisis. On the other hand, the Ministry of Health, in spite of a balanced head start, suffered a series of important budget cuts and remained under-funded until the 1990s. With its funds, and the uncontrolled use of pension funds, IMSS built an important health infrastructure in urban and industrial areas.⁵⁹ This, plus its financial autonomy *vis a vis* the government—due to employer/employee mandatory contributions—has helped it maintain its predominant role in Mexico's health sector. Throughout the years, the IMSS bureaucracy, through its union (SNTSS), has built an important base of support among IMSS affiliates, the formal workers, and politicians with links to the official party, and thus in positions in the Executive, the Legislature, and state and local governments.

Using occupational criteria to determine a citizen's access to health services has divided the system in three clearly differentiated and vertically organized sectors, each providing and financing its services under different rules. The IMSS is the principal social security provider; the Ministry of Health services the population lacking social security. Finally, the private sector is available to those who can pay (see Diagram 2).

⁵⁹ The sole exception being the northern industrial states, where instead of building infrastructure, IMSS allowed most companies in the region to procure health services for their work force in the private sector and reimbursed them their quotas in what is called the opt-out option.

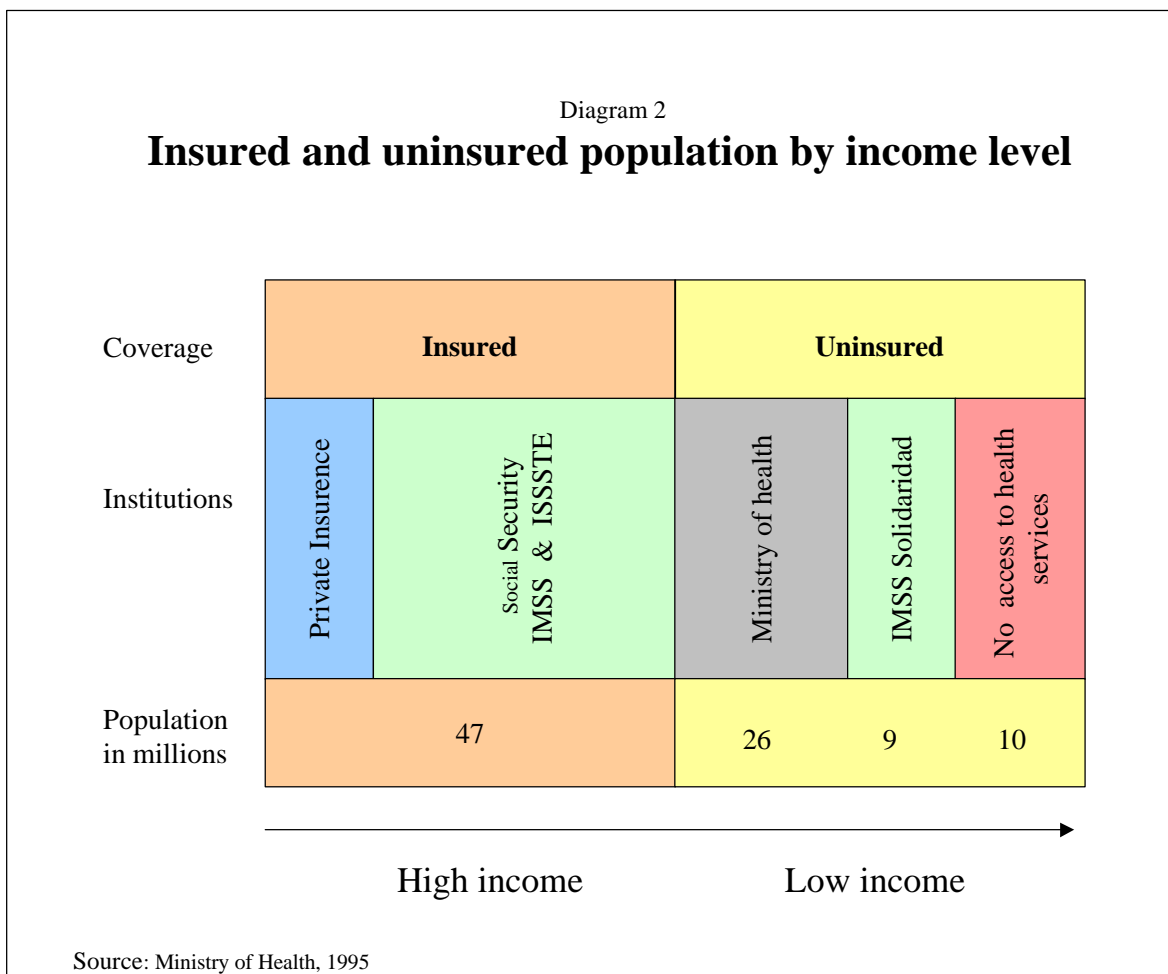

In 1954, there was an attempt to incorporate rural workers into the IMSS, following the State's promotion of commercial agriculture. However, due to rural labor dynamics—most of it requiring temporary migrant work—and the agricultural workers' poor political mobilization, these groups were not effectively incorporated into social security, and by 1958, agricultural workers represented only 7% of the total number of insured members.

During the early 1960s, in response to the growing pressure of the urban middle class, and particularly the State's bureaucracy, the State Workers' Social Security and Services Institute (ISSSTE) was founded. The creation of the ISSSTE in addition to the IMSS, consolidated the State's provision of health care through separate institutions for particular target groups and converted social security into the principal form of State participation in the provision of health care. This was to the detriment of the Ministry of Health's services and worked against the possibility of creating a single health care system around criteria of citizenship, instead of occupation.

In the 1970s, the Echeverria administration responded to the legitimacy crisis that resulted from the violent repression of the 1968 student movement with a series of political and economic concessions to organized interest groups. The Social Security Law was thus reformed in 1973 to extend its coverage to groups that had previously been excluded, but who at that time were considered politically and economically important. Faced with a shortage of funds to offer an integral package of services, IMSS established a special set of regulations by which these new

groups could be incorporated, but entitled to fewer services.

For instance, IMSS started servicing specific groups of rural workers in the informal sector selected at the discretion of the government, through a special program in which the benefits package was very reduced when compared to the regular service. According to the criteria by which the target population had been divided, these groups should have been handled by the Ministry of Health, since they were not formal workers. However, given the comparative advantage the IMSS had built, financial factors made the government determine that health care to these rural groups be provided by the IMSS, instead of the Ministry of Health.⁶⁰

As part of the State modernization effort that accompanied structural adjustment in the 1980s, a health system reform was started during the De la Madrid administration (1982 – 1988) to improve the efficiency and quality of services, and to improve equity in access to them. It included the decentralization of the Ministry of Health's facilities and the formation—via the merging of rural IMSS services and MOH facilities—of state-level health care systems. It also sought to strengthen and increase the decision making and leadership capacity of the Health Ministry as head of the health sector. This policy would have implied a change in the balance of power between the MOH and IMSS, since while formally the Ministry of Health was the head of the health sector, the IMSS outweighed it in the financial, organizational and political fields.

However, as the economic crisis worsened, the government was forced to reconsider its reform priorities in the public agenda. The President and his economic team focused their attention and political capital on limiting the economic crisis and accelerating structural adjustment in key areas such as the privatization of state enterprises and commercial liberalization. Furthermore, a veto coalition was soon formed around the IMSS leadership, with the IMSS union playing a major role alongside the IMSS directors. These actors felt their exclusive access to social security benefits and services was being threatened. As a result of this stark opposition to the health reform agenda and the economic crisis reaching a peak in 1985, the De la Madrid government took the decision to bring the decentralization process to a halt with only 17 out of the 31 states having completed the process.

The further weakening of the corporatist pact that resulted from the economic crisis of the mid-1980s and the structural adjustment measures, led to an effort by the incoming Salinas administration (1988-94) to rebuild—or reconfigure—the State's coalition of political support. President Salinas started his administration with a complex political strategy of carrot and stick aimed at sending a clear signal that the technocratic group in power would confront the old corporatist feuds, particularly the unions, that opposed it, while not touching the interests of those that cooperated or did not interfere with the government's agenda. Thus, a few weeks after taking office, President Salinas had the powerful leader of the oil workers union jailed in a very visible maneuver, he quietly ordered any attempt at continuing with health reform, which was not in the interest of the IMSS union, stopped (Interview, 18/10/00).

Simultaneously, in an attempt both to reconstruct the political tissue and to create a coalition that would serve as a counterweight to the old corporatist apparatus, President Salinas tried to incorporate those groups in the informal sector that had historically been marginalized from political participation and had little access to public services. He thus launched new public

⁶⁰ The size of the IMSS infrastructure and its administrative capacity, permitted it to absorb new groups at a lower *per capita* cost than the SSA. Also, the fact the IMSS services were financed by tripartite funding permitted the government to expand coverage without putting more pressure on the already strained government expenditure balance.

programs establishing new parameters structuring State-society relations. The most visible and politicized of which were related to development and the social sphere (Dresser, 1994).

To do so, and to circumvent the vested interests entrenched in the social sector's bureaucracy, his government established the new social programs under an umbrella program called *Solidaridad*. This multi-sectoral program was directed at poverty alleviation and local development through the mobilization of the target population and participatory schemes. The technocrat's search for a new base of political support by breaking up old corporatist privileges and increasing access for the population at large, made reforming the IMSS and moving toward more equitable and inclusive health care, a natural item on the agenda. However, the IMSS was only made to participate in the new social policy strategy by re-labelling its health program for the rural uninsured population under the banner of *Solidaridad*,⁶¹ and access to secondary and tertiary care remained exclusive to its regular affiliates—the formal work force.

The government's choice to maintain the privileged access of the formal workers and, most significantly, to leave the interests of the IMSS bureaucracy untouched, can be traced back to the failure of the Salinas administration to consolidate its new political base of support. In spite of the new network of fresh channels between the State and the new politically mobilized groups that it had created, the absence of tangible positive results in the economy for the majority of the population, and the resilience of the corporatist pact as the central element in State-society relations, led the technocratic team in power to maintain some of the old bastions of the corporatist machine.

Also, the real possibility of having some of the old official unions change alliances and move to the new opposition parties (particularly the PRD) was met by PRI members and the technocrats with concern, and thus the government made concessions that included delaying – or derailing – what it perceived as “non-essential” reforms that were against the unions' interests, in order to secure enough political stability to pursue the economic reform agenda. Thus, in spite of the wave of renewal of State-society relations in the social sector, President Salinas decided not to reform the IMSS, the most visible representation of the old exclusive corporatist pact.

Having said that, while the health component of IMSS was thus left untouched, the economic team in power regarded the reform of the pension scheme as part of the economic reform that was given priority. Thus, a first attempt at reforming the pension system took place as part of an effort to consolidate the structural adjustment program. However, as opposition to the pension reform mounted, the Salinas administration became concerned with the possibility that it might affect the political feasibility of its most crucial project: the approval of the Free Trade Agreement with the United States (NAFTA). The scope of the IMSS pension reform was thus reduced accordingly: instead of substituting the pay-as-you-go government pension scheme under IMSS control with a private pension scheme, a private pensions system (SAR) was set in motion as a parallel scheme to that of IMSS. The economic team at the Finance Ministry and the Central Bank, was not satisfied with the partial scope the pension reform attained, and thus continued to explore policy options to complete the privatization of the pension scheme.

Another important element influencing the Salinas administration decision not to reform IMSS, is that it had planned its reform and structural adjustment agenda on a time horizon that comprised at least two government terms – twelve years. During his administration, first generation reforms; i.e., those related to the economic sphere, were to be consolidated, while in the following administration, the second-generation reforms were to be implemented: Those related to the social sector.

⁶¹ Thus IMSS rural program was relabelled “IMSS-Solidaridad.”

However, when President Ernesto Zedillo (1994 – 2000) began his term in office, the country was immersed in a severe economic and political credibility crisis. As a result, his government concentrated its policy agenda on solving the short-term financial and macroeconomic crisis. Although the new economic team had been preparing the government program during the previous administration in which its members held key positions-, it became necessary to reformulate the reform agenda and overall planning, and adjust the proposals to the new circumstances.

THE HEALTH SECTOR REFORM PROGRAM (PRSS)

The Health Sector Reform Program (PRSS) 1995-2000, which was presented as part of the National Development Plan, was thus promulgated in a context of economic crisis. Nonetheless, it still presented a very ambitious action plan that considered a long-term horizon beyond the administration's six years in office. Regarding health services provision, both documents identified the vertical segmentation of the health system and the division of the target population according to occupation, as an issue to be addressed, and both stated that, in the long run, a horizontal segmentation of the system according to functions was desirable.⁶²

The Reform Program of the Health Sector states the following fundamental goals,⁶³

- To establish instruments that promote quality and efficiency in the provision of services.
- To expand social security coverage through mechanisms that make affiliation easier to non-employed population and to those belonging to informal economy.
- To decentralise health care provision to the uninsured population in those states where it was still centralized.
- To expand health care coverage to the very poor residing in rural and urban areas who at the time had limited or no access to public health services.

The economic team's intention was to rationalise the provision and financing schemes of health services, targeting health subsidies to the poorest segments of the population (Diagram 3). To that object, the Program contemplated the need to reform the Social Security Law in order to create a Family Health Insurance (SSF) to which the State would allocate a per capita subsidy financed with public funds, for the informal workers willing to become affiliated through the payment of an annual fee. In this way, the population groups who had purchasing power, but who do not belong to the formal economy, could be incorporated to social security.

The reform plan also considered an increase in the government's share of the tripartite quota that finances the IMSS health services. This was intended to support IMSS health service's faltering financial equilibrium, which was to worsen with the privatization of pensions, and thus avoid the need to increase employer and employee contributions. This was considered by the economic team as a policy to protect producer competitiveness in the world economy, since it helped keep labor costs down. Also, as a result of the rise in the government's share, it would become feasible to subscribe more opt-out and quota reimbursement agreements with private

⁶² Poder Ejecutivo Federal, *Plan Nacional de Desarrollo 1995-2000*, México: 1995, pg. 93 and Poder Ejecutivo Federal, *Programa de Reforma del Sector Salud 1995-2000*, México: 1995 pg. ii and pg. 20. For further details, see Funsalud, *Economía y Salud*, pp. 39-47.

⁶³ Programa de Reforma del Sector Salud 1995-2000, pg. 14.

Diagram 3
Population Distribution by Agency

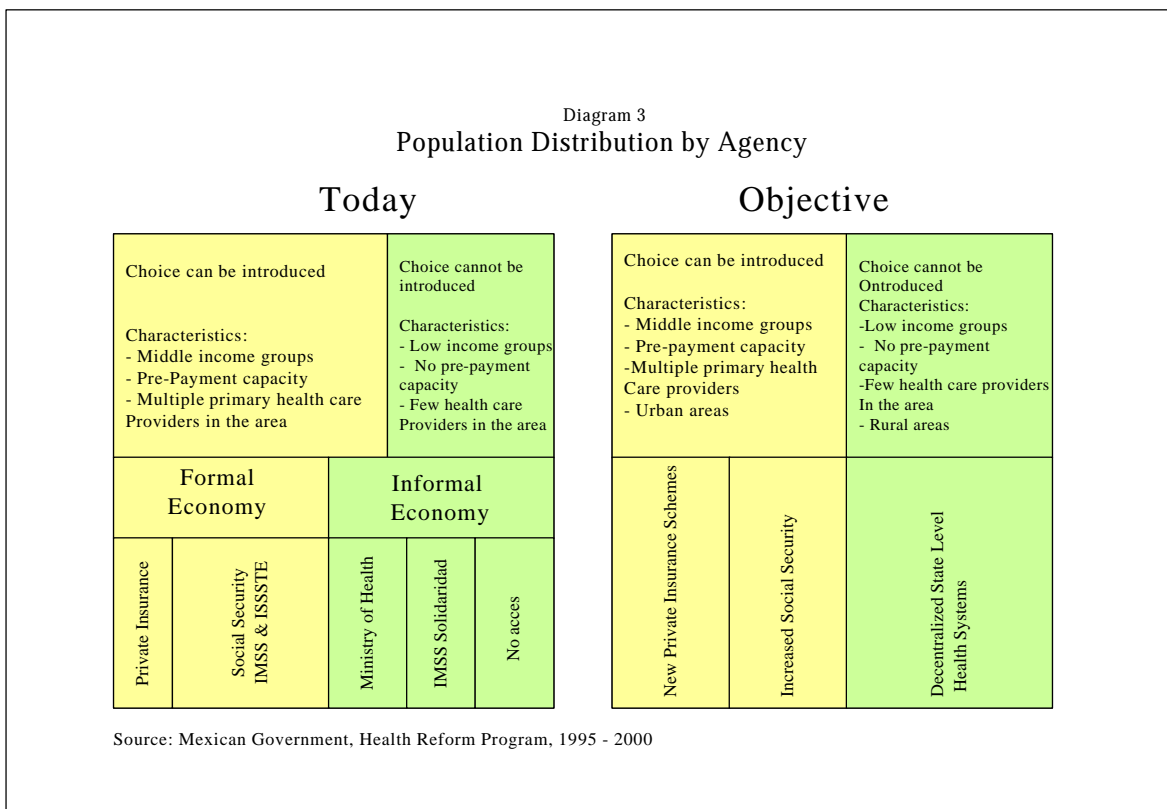

firms,⁶⁴ without jeopardising IMSS' financial equilibrium, since the government's quota is not subject to reimbursement.

Regarding the decentralization process, the Program states that the decentralization of federal resources destined to the uninsured population, which stopped in the mid 1980s, should be reactivated. There should also be the creation of state-level health systems through the merging of local MOH facilities and those of IMSS-Solidaridad. While the decentralization of MOH facilities did take place, the merging of IMSS-Solidaridad facilities did not occur. Instead, IMSS followed its own internal deconcentration process through the creation of seven regions with autonomous responsibilities and functions.

Finally, in order to reach the close to 10 million people with limited or no access to health care, the Reform Program proposed the implementation of a "basic service package" composed of essential cost-effective health interventions with high impact,⁶⁵ under the responsibility of the MOH.

⁶⁴ The opt-out and quota reimbursement policy is a mechanism by which the Institute returns a percentage of the worker-employer quota to those firms that have contracted with private health insurance for their employees. Although reimbursement has been possible in theory under the IMSS Law since 1943, in practice it has seldom happened because the law's lack of precision about the requirements has opened the door for discretionary decisions around which firms may be subject to quota reimbursement. IMSS has been reluctant in the past to apply it due to the union's stark opposition – and thus its political consequences, and because of its possible negative impact on IMSS' health fund finances.

⁶⁵ Programa de Reforma al Sector Salud 1995-2000, pg. 18.

SOCIAL SECURITY REFORM

While the reform of the health component of social security was formally considered as part of the sector-wide health reform Program (PRSS) under the leadership of the MOH, IMSS' autonomous status and its political and organizational weight within the sector gave it enough leeway to define and implement its own reform agenda away apart MOH's influence. IMSS' size, the amount of its financial resources, which it collects and manages independently from other government agencies, and the size of its target population, had made it a central and independent actor within the health sector with, *de facto*, more power than that of the MOH. Thus, while formally the IMSS was required to discuss policy guidelines with the Minister of Health, in reality it established its own policy agenda, and undertook policy negotiations directly with other government agencies—notably the economic team at the Finance Ministry and the President's Office—as well as with state and local governments. It also managed independent contacts with other actors in society, such as business groups who have a stake in IMSS, since they are required to pay quotas and are a formal part of its board, and its own public opinion strategy, where it presented itself as an actor independent of the rest of the health sector.

Another phenomenon moved the locus of decision making relating IMSS reform further away from the MOH, and closer to the Finance Ministry. And this was the fact that the economic team considered IMSS' pensions reform a part of the economic reform. It was the economic team's interest in pensions what brought the reform of IMSS' health component to its attention. The economic team's perception of IMSS pensions reform as part of the economic reform, and thus within the scope of influence of the Finance Ministry, had two effects. First, as the technocratic team felt that the economic reform had been mostly completed, and was turning its attention to the social sector, IMSS reform presented a "bridge" between the economic and the social spheres, as it had both an economic component and a social component to it. Secondly, this explains the financial approach that was used to both articulate the policy problems IMSS' health service provision faced, and the policy responses to them that were included in the reform agenda.

IMSS policy problems, as they were perceived by the economic team in the mid nineties included its financial viability being at risk in the short term as a result of inefficient resource management; the demographic and epidemiological transition its target population was undergoing;⁶⁶ an inefficient provision of health services; an oversized bureaucracy and centralism in service provision administration; inadequate performance incentives; a rigid collective contract with its work force; and complex labor relations with the IMSS union. Furthermore, discussion between the economic team and other actors involved in the IMSS assessment were leading towards the idea that employer quotas were high by world standards; thus putting producers' competitiveness in jeopardy in the world market. According to this perception, high quotas were also leading to under-declaration, lack of incentives to create formal employment, and fraud. The fact that only a part of the population had access to IMSS' health services—limited to formal workers and their families—was also acknowledged. It had become clear that expanding IMSS coverage through the obligatory incorporation of new formal workers as economic growth was

⁶⁶ Among the most relevant demographic changes are: rise of life expectancy, decrease of birth rate, and increase of the population's average age. The epidemiological transition consists in: decrease of infectious illness and increase of the chronic-degenerative sicknesses.

reassumed, and new jobs were created would take a long time. Therefore, for the first time, the possibility of incorporating non-formal workers through a voluntary insurance scheme was considered.⁶⁷

The *Diagnóstico de la Situación del Instituto Mexicano del Seguro Social*⁶⁸ pointed at the problems in the financial and organizational aspects of IMSS health service provision. Before the 1995 reform, the IMSS had four insurance funds to which the Retirement Savings System was added in 1992. The funds and their financing sources were the following:

Table 1 Social Security Insurance Funds

FUNDS	QUOTA SHARE*	CONTRIBUTION
IVCM** (pensions)	8.5 %	Tripartite***
Illness and Maternity (health component)	12.5 %	Tripartite
Work Hazards	2.5 %	Tripartite
Day Care	1 %	Employer
SAR	2 %	Employer
TOTAL:	26.5 %	

* Of the base salary.⁶⁹

** Disability, old age, old age severance and life insurance.

***The tripartite contribution was divided into: 70% employer, 25% worker, and 5% government.

Although it was necessary to reform the first four components of social security, pensions and health required the most urgent and profound restructuring. By the mid-1990s, pensions (IVCM) were in severe financial disequilibrium,⁷⁰ since the reserves had been depleted and used for IMSS infrastructure and to meet the health services provision running costs. As a result, before the reform, retirement pensions were being met with active workers' quotas. However, due to the increase in life expectancy, the change in the age structure of formal workers, and the increase in the package of benefits without a corresponding increase in insurance premiums, the resources destined for this pay-as-you-go system, were insufficient.

The Illness and Maternity insurance also faced serious financial and service provision problems, due to the fact that when IMSS was created, the original quota for this fund was estimated on the basis of health service costs solely for the worker, and not for his relatives. But workers families were also covered, so as a result, the health insurance faced financial problems from the start. Over time, benefits in health care were also increased without adjusting the quotas, furthering the financial disequilibrium. The gap was met by the pensions fund. However,

⁶⁷ CEDESS, *Proyecto Águila*. Presentation of December 20, 1994, pp. 33-35.

⁶⁸ IMSS, *Diagnóstico*, March, 1995.

⁶⁹ The elements that constitute the base salary are established in Article 27 of the New Social Security Law.

⁷⁰ According to IMSS projections, by the year 2000, the expenses of this insurance fund would be greater than its income, so the deficit would have to be compensated with the financial reserves accumulated during the previous years. The problem would be prominent by the year 2004 when the reserves would be exhausted and other fund sources would be necessary to balance the IVCM's finances. IMSS, *Diagnóstico*, March, 1995, pg. 62

the financial difficulties of the pensions fund made it impossible to continue with this cross subsidy. Another factor that negatively affected the health insurance's finances was that quotas were indexed to wages, and not to costs.⁷¹

IMSS REFORM OBJECTIVES

In accordance to the government's neo-liberal stand, the solutions set forth for the restructuring of the pensions system, the financial reorganization of IMSS insurance funds, and the improvement of health service provision, were formulated with the premise that efficiency and quality are generated by market (or quasi-market) mechanisms and competition.

The stated goals of IMSS reform were:

- To fully privatize the pensions system in order to promote the country's internal savings, while at the same time ensuring the long-term financial equilibrium of IMSS.⁷²
- To reorganize the financial structure of the IMSS to guarantee the agency's financial stability with the elimination of cross-subsidies and adequate quota levels for each insurance component.⁷³
- To improve the quality of health care provision through the introduction of such measures as doctor eligibility in the first level, permanence and productivity incentives, and the application of the opt-out option.

PROBLEM DEFINITION AND REFORM FORMULATION (1992-94)

Beginning in the early 1990s, a variety of groups in society and within the State started to consider different policy options to reform the health sector in its totality, or at least in one of its central components—the health services provided by IMSS to almost one half of Mexico's total population. These groups' initiatives, and indeed their own nature, changed over time as the process of health reform unfolded; but based on the basic characteristics of their proposals and the political context in which they operated, they can be divided into three groups.

First, there was the technocratic group that emanated from the government's economic team. This group was assigned to the IMSS financial directorate and it was their proposal that was to prevail, with some influence from the other two groups. Second, CEDESS, the group within IMSS, more specifically, within its senior directorate, who lost the battle to define the reform's content, but was indispensable to make the first group's technocratic proposal politically feasible. Third, a heterogeneous group formed by a private think tank representing the

⁷¹ Ibid, p. 31.

⁷² Reformers also thought that the privatization of the pensions system would help to limit the political handling of the Institute's resources, since resources would cease to be deposited in a general fund, and instead would go to individual accounts.

⁷³ The contracting out of services was also considered as a means to lower service provision costs. Administrative decentralization and layoffs of low and middle level personnel were on the agenda as well.

interests of the business community (Funsalud) and another one formed by members of the Ministry of Health.⁷⁴

The first group was well embedded within the State, particularly within the core ministries that define economic policy. The second group was in the periphery of the State, as part of an autonomous State agency, although it had contacts with the economic team. The third group stemmed in part from society, but had strong links with several policy makers within the State.

THE ECONOMIC TEAM AND THE IMSS CHANGE TEAM

IMSS was regarded by the economic team as a large government agency in financial distress that needed to be reformed as part of the efforts to bring the State's finances back to equilibrium. Not only did it face bankruptcy—a crisis to which the State would have to respond, but it would soon fail to meet its pension commitments with workers that were about to retire. Responding to what was seen as an imminent crisis, members of the economic team in the Finance and Commerce Ministries started studying the case and formulating policy proposals in the early 1990s. Although some IMSS officials participated, most of the research leadership and resulting reform proposals stemmed from the Finance Ministry and the Central Bank (Bank of Mexico). The IMSS Director at the time, Emilio Gamboa Patrón, was kept informed of the project's development, but neither he nor his close collaborators were directly involved.

The Finance Ministry's proposal was not the only one that was formulated within the Executive at this time. The IMSS issue was important enough to quickly become an element of competition among the economic team's factions, who were positioning themselves to compete for the presidential succession.⁷⁵ Thus, in a parallel way, the chief of staff of the Presidency entrusted public officials from the Commerce Ministry to work on an alternative proposal (Interview, 04/08/99). The Finance Minister's team finally lost control of the project, which was assumed by the Finance under-secretary, Guillermo Ortiz – who belonged to the *camarilla* of the President's chief of staff. Ortiz and his team worked with the close collaboration of the officials at the Commerce Ministry.

The resulting pension reform proposal substituted a private scheme of fully funded individual retirement accounts for the government's pay-as-you-go pension system. Also, as part of the government's promotion of sound fiscal policies, the Finance Ministry decided to promote the financial reorganization of the other IMSS insurance funds and benefits as well, thus including the financial aspect of IMSS health service provision (i.e., the IMSS health component). The sole objective was to guarantee the agency's financial stability and to induce a more efficient use of resources.

As the reform proposal gained form, some of the members of the technocratic group that had gained control over the project were assigned to positions within IMSS to work on its technical details. They also prepared for its implementation, which was planned to occur during

⁷⁴ Other groups in society, particularly an academic group from the Xochimilco Autonomous University, had been studying the health care system for years, and publishing policy recommendations. However, these groups did not present formal policy documents with reform proposals as the others did. Therefore, they did not have an important presence in the policy debate and the political struggle that evolved around the health reform process. For details on their policy positions, see Laurell (1994).

⁷⁵ Also, the Presidency promoted competition between factions as a means to drive forward more "efficient" proposals, to limit the power of the different groups within the government, and to consolidate its own power.

the coming administration. Among them was Gabriel Martinez, an economist who, as a junior member of the economic team working in the Commerce Ministry, had participated in important deregulation projects,⁷⁶ and was aware of the discussions around IMSS reform. At Commerce Minister Serra Puche's recommendation, he was assigned to the IMSS Financial department to a position whose appointment was controlled by the Ministry of Finance⁷⁷ (Interview, 02/24/99). When President Zedillo was elected, it became clear that Minister of Commerce Serra Puche would be the future Finance Minister. When this indeed happened, Gabriel Martinez and his team counted on the direct political support from the Finance Ministry—a key vertical link in their network.

Under these circumstances, and with a clear mandate to pursue IMSS reform along the lines defined by the economic team in the Finance and Commerce Ministries, Gabriel Martinez put together a change team of very young professionals with training in economics and accounting, but no previous experience in health or the social sector. The change team faced resistance from the IMSS bureaucracy and from its directors, who perceived it as foreign to the Institute and an intrusion from the economic team in the Finance and Commerce Ministries (Interview, 04/04/97). And indeed, this change team made little effort to establish a network within IMSS. Instead, it concentrated in moving as swiftly as possible with the financial reengineering of IMSS insurance funds and the other components of IMSS reform, and continued to work very closely with their peers in the Finance and Commerce Ministries. These were all links in their horizontal network.⁷⁸ This change team, however, was soon to lose its single most important vertical tie with the resignation of the Finance Minister, Serra Puche. Following this, and as part of the change in strategies it was constrained to follow, the team made efforts to establish a network within IMSS, particularly with the IMSS union.

The CEDESS

The takeover of the project by this new faction of the economic team coincided with a change in the IMSS top management. Emilio Gamboa Patrón was replaced by Genaro Borrego Estrada as the Institute's Director. Borrego's arrival to IMSS represents a breaking point in the reform process. Although he was not a technocrat, and had had a long political career in PRI, Borrego presented himself as a policy maker with the necessary combination of political and the technical skills to bring about the social security reform. Thus, he decided to participate directly and actively in the restructuring of the social security system. In order to do this, he sought to generate a technocratic reform proposal of his own that, as a trade mark, would go beyond the financial aspects of IMSS and present an integral reform for IMSS (Interview, 03/22/99).

Borrego surrounded himself with a group of economists and actuarial experts with similar technical training and ideology as the technocrats in the Ministry of Finance, and placed them in key positions within the IMSS. He created a think tank in mid-1993, called the Centro de Desarrollo Estrategico para la Seguridad Social (CEDESS) that was assigned the responsibility of studying policy options. CEDESS formulated a more integral reform proposal that went beyond the financial restructuring of the Institute, and included an in-depth change in health service delivery. CEDESS was formally separated from IMSS, and in practice operated as a think tank for the Institute's directors. Its purpose was to isolate the formulation and development of reform

⁷⁶ Notably telecommunications.

⁷⁷ Following an tacit agreement between both agencies, the assignment of this position had been under the control of the Finance Ministry for many years.

⁷⁸ Notably with Santiago Levy, the Finance under-secretary in charge of social sector budget allocations.

propositions from possible external pressures, especially from the Institute's bureaucracy. (Interview, 03/22/99). The Center was perceived by its members, and by the IMSS directors as a space away from the pressures of bureaucracy where researchers 'dared to think' (Interview, 02/25/99). The CEDESS team not only was in charge of presenting a technocratic proposal in similar terms as that being prepared by the economic team in the core ministries—thus facilitating closer links with this group, but to create the means to have the IMSS reform process gravitate back to IMSS' control.

CEDESS was integrated by a multi-disciplinary and apolitical team that aimed at generating new, "uncontaminated" proposals for social security reform (Interview, 04/22/99). A small number of technical government officials—some of whom had been academics and/or consultants—constituted the different work groups on pensions, health, labor risks, and day-care centers.⁷⁹ Most significantly, CEDESS counted on the collaboration of consultants and public officials who were trusted by the economic team, and shared some level of cooperation with the policy makers working on the proposal both at the core ministries and in IMSS' change team, led by Gabriel Martínez.⁸⁰ During many months, there was extensive exchange of information and analysis, but this did not develop into a cooperative relation on equal basis and only the few members of CEDESS who were also close collaborators of the economic team members circulated freely from one team to the other. In the end, while most of the actuarial work and part of the economic analysis was carried out at CEDESS, the economic team and IMSS change team were in control of policy decision making and of access to it.

Between 1993 and 1994 the CEDESS team worked on a series of projects regarding the IMSS reform agenda. The studies prepared by this group include the *Proyecto de Gran Visión*, which contemplated a wide range of policy options from the most radical to the most moderate; and *Proyecto Águila*, derived from *Proyecto de Gran Visión*⁸¹ that, according to the CEDESS team,

⁷⁹ The pensions group was headed by Enrique Dávila, former economics professor at the Autonomous Technological Institute of Mexico (ITAM) and Santiago Levy's collaborator in the Economic Deregulation Unit of the Commerce Ministry (SECOFI). Santiago Levy, who at that moment was Director of the Federal Competence Commission, was interested in Enrique Dávila's incorporation into CEDESS to promote proposals with a solid microeconomic basis. The labor risks team was headed by Jorge Rendón, who had been director of the Actuary Course in ITAM. The health team was headed by an IMSS physician, Dr. Mario Villafaña.

⁸⁰ Indeed, Gabriel Martínez, head of the Economic Deregulation Unit of SECOFI at the time, had contact with the work being developed at CEDESS regarding the reform (Interview, 03/11/99).

⁸¹ The *Proyecto Águila* was a document of restricted circulation.

represented the best alternative for IMSS reform. In it, the CEDESS team compiled their assessment of social security in Mexico and their reform proposals.⁸² For the IMSS health component, the *Proyecto Águila* included among its stated objectives the need to achieve financial self-sufficiency of IMSS' health service provision (the Illness and Maternity fund), to increase quality and efficiency in service delivery, and to expand coverage to all the employed population regardless of occupational status—formal or informal.⁸³

To reach these goals, the document proposed the reorganization of the health component's financing and service provision. For instance, in the case of the objective to achieve long-term financial equilibrium in the Illness and Maternity fund, *Proyecto Águila* suggests substituting a fixed quota for the quota estimated as a percentage of the worker's salary. This fixed quota would be adjusted for inflation in which the State's share would increase and the employer and employee contributions would decrease. The financing scheme of the Illness and Maternity fund proposed by the *Proyecto Águila*, in comparison with the one prior to the reform, was the following:

Table 2

FINANCING SCHEME IN FORCE BEFORE THE REFORM	PROYECTO ÁGUILA'S PROPOSAL
12.5% premium of the base salary	Fixed quota adjustable according to inflation
Tripartite contribution:	Tripartite contribution:
EMPLOYER: 70%	Employer: 60%
Worker: 25%	Worker: 15%
Government: 5%	Government: 25%

⁸² CEDESS' researchers worked on this project from mid-1993 until the end of 1994. With respect to the IVCM insurance, the document established that the reform objectives were: to ensure financial self-sufficiency in the long term; to reduce the insurance cost for firms in order to favor competitive capacity; to cover a considerable segment of the retired population; to give equal treatment to different insured groups; and to grant economically sufficient pensions.

In order to reach the objectives it proposed, in first instance, to stop fund transfers from IVCM to Illness and Maternity. Second, to separate quotas destined for retirement pensions from the non-labor risk insurance (severance and life insurance) by creating two different funds. The retirement insurance would be transformed from a pay-as-you-go system, in which the active workers financed the retired workers, into a system of fully funded individual accounts, in which each worker saved in a single fund. CEDESS, *Proyecto Águila*, pp. 59-77.

The economic advisors to the presidential candidate, Luis Donaldo Colosio, did not support the idea of transforming the pensions system into fully funded individual accounts. Nor were they in favor of establishing a fixed quota as a financing scheme for the Illness and Maternity component. However, Colosio died in March, 1994. From the moment Zedillo was nominated as the PRI candidate to the Presidency, it was clear to CEDESS' researchers that the future president's line regarding the pensions system would be in the direction of fully funded individual accounts (Interview, 04/16/94).

⁸³ *Proyecto Águila*, pg. 46.

The CEDESS researchers' proposal sought to eliminate cross subsidies between contribution levels and the distortions it caused.⁸⁴ In their opinion, the implementation of a fixed quota would also make the opt-out policy viable.⁸⁵

With regard to health care provision, *Proyecto Águila* proposed doctor eligibility, not only among IMSS doctors, but among any doctor who complied with the Institute's requirements (Interview, 04/16/99). At the first level, doctors would be independent—under the Institute's norms and regulations—and would be able to hire their own support personnel. Their incomes would be in accordance with the number of insured persons that selected them. This would in practice open up IMSS services to a public-private mix of providers in which doctors would cease to be employees and would be paid on a capitation basis.^{86 87}

According to the *Proyecto Águila*, the change in the provision of health care service would have a series of positive impacts, including better quality service quality resulting from competition among doctors; increase in doctors' income as the number of patients under their responsibility increased; reductions in labor cost through a lower employer quota, which would translate into lower labor costs; and the possibility of fulfilling the opt-out and quota reimbursement agreements.

In spite of CEDESS collaboration with the economic team and the change team in the IMSS Finance Department, IMSS director's attempt to take control over the reform's formulation failed. The IMSS top management was only given a major role when the economic team had finished its reform initiative, and needed to broker it with key interest groups—notably business and labor, and the IMSS union—and in Congress, when the initiative was presented for legislation. Some significant changes were made to the economic team's reform proposal

⁸⁴ In Dávila's opinion, cross subsidies between income groups of beneficiaries could not be justified as an income redistribution mechanism, because its fairness was questionable. Informal workers were excluded from these health services, and high income individuals who obtained their income from interest, dividends, or professional fees did not participate. Furthermore, Davila also considered that the financial stability of the IMSS health component was also negatively affected by the distortions generated by the quota collection system. Cross subsidies generated incentives among the most qualified individuals to work independently, and among firms to hire high salary employees as free-lancers. Also, they induced under-declaration of salaries because contributions above the basic wage were perceived as a tax – since access to health service was the same, regardless of the insurance premium. Finally, cross subsidies represented, in practice, an obstacle for quota reimbursement, since as the system stood, the high income workers would be the first ones to opt out if the policy was applied, and this would throw IMSS back into financial disequilibrium. For a more detailed account of the distortions that were generated by the financing scheme of the health component before the reform and their consequences for IMSS, see Davila (1997).

⁸⁵ Quota reimbursement would help relieve cross subsidies by selection of medical services, from workers who contributed without making use of IMSS' facilities toward the rest of the contributors. Ibid., pg. 17.

⁸⁶ *Proyecto Águila* suggests that support services such as pharmacies, laboratories, and x-ray diagnosis be contracted-out so the insured person can receive the services on the IMSS premises or in any other private institution, by presenting the prescription issued by the Institute's doctor.

⁸⁷ In *Proyecto Águila*'s proposals to transform the medical care service, many of the layouts from the *Modelo de Medicina de Familia* can be appreciated. The model had been developed by the CEDESS' medical team led by Mario Villafaña. The model establishes the following fundamental principles to achieve adequate health care services in the family medicine level: doctor eligibility; capitation payment; permanent attention -24 hours, seven days a week- through cooperative doctors teams. The *Modelo de Medicina de Familia* as is the case with *Proyecto Águila*, suggests health insurance financing through a fixed and equal quota for all workers, and quota reimbursement permitted to those firms that contract a private insurance for their workers. Both projects favor subrogation of services -operating personnel included- to private purveyors.

influenced by IMSS arguments on political feasibility during negotiations with different actors through-out the reform process, but the project remained firmly in the hands of the economic team, who saw in Martínez' change team an extension.

OTHER GROUPS IN THE STATE AND IN SOCIETY

In the light of the change of administration that was to happen in 1994, and with the aim of influencing policy decision making in this field, two additional groups started studying and preparing policy proposals for health reform. These groups included one coordinated by the MOH Planning Under-Secretary Jaime Sepulveda, and another which worked at a private think tank called The Mexican Health Foundation (Funsalud).

Planning Under-Secretary Sepulveda was perceived as a possible successor of the Minister of Health, and thus he and his team set out to position themselves by conducting a series of polls to build a data base for a health reform plan. His group also published, as part of MOH publications, a series of small booklets addressing some of the issues relevant for the health sector. However, due to lack of human capital to prepare a complete technical proposal and given that the group did not count on a close ties with other policy makers in the core ministries working on the issue, these publications did not form a single body of work that could come together as a health reform proposal.⁸⁸ In line with its political agenda, this team participated in a group organized by the PRI – called Grupo Coordinador en Salud – with the task of putting together a white paper on health as part of the PRI's electoral platform for the presidential race. However, when the team's leader was not assigned to the MOH, it was quickly dismantled as such and its members resumed research activities at the National Institute of Public Health.

Funsalud conducted a two-year project called *Economía y Salud* (Health and Economy), led by Julio Frenk. This group produced a comprehensive health sector proposal that envisioned major changes in both the Ministry of Health and the IMSS. It aimed at establishing a single system with a plurality of public and private health service providers, where the Ministry of Health would be responsible for policy guidelines and regulation, while the IMSS would be in charge of health service financing.

Funsalud's project was the first case in which a highly visible and comprehensive policy proposal was presented in the public arena by the private sector through a group of businessmen that aspired to influence the public policy agenda in the area of health. This group was dissatisfied with the financial burden that the social security obligatory contributions put on the private sector and by the poor quality of the services received by their labor force. Thus, they funded Funsalud's *Economía y Salud* project with the aim of presenting in an articulate manner elements regarding the why and how of the need for IMSS reform. In particular, they emphasized its downsizing and the possibility of substituting for its services with private provision of health care via the opt-out policy as part of a comprehensive health sector reform.

On his part, Frenk conceived the idea of the *Economía y Salud* project when he collaborated in the preparation of the World Bank's *World Development Report 1993*, which had health as its main topic. Thus the *Economía y Salud* proposal went beyond an assessment of IMSS performance, and addressed issues central for the entire health care system, such as equity, efficiency, and quality. It presented policy solutions along the lines that were being discussed in the international arena, such as the health care system's reorganization by functions, as opposed to

⁸⁸ Cuadernos de Trabajo, SSA, Nos. 1 – 32, Mexico 1994.

specific target populations – thus eliminating vertical segmentation—and the use of quasi-market and competition elements to induce efficiency and better quality of care.

As the proposal was being prepared, the businessmen lobbied in favor of their health reform agenda resorting to a direct approach to policy makers in government - including Finance Minister Aspe. Aspe shared the same ideology and was seeking to find policy solutions to diminish the size and presence of the State in social services provision and a more active role for the private market as a means to attain a more efficient use of public resources. Thus the economic team in power responded with important information and support.⁸⁹ This was particularly the case for the Finance Ministry's faction that was then in charge of analysing IMSS reform. This team found in Funsalud a space outside government that was insulated from interest groups, in which different reform proposals could be studied and debated with no constraints or political considerations. Funsalud was also a structured organization that had the financial and political resources to promote a reform proposal with which they shared a common ideology.⁹⁰

Among the proposal's elements that permeated the official health reform documents of the Zedillo administration⁹¹ were the need to attain universal coverage by the year 2000 through the implementation of essential health service packages, the need to establish doctor eligibility as a means to create competition and incentives for better performance, and the need for a clear strategy to raise quality and efficiency in the health organizations including reinforcement of management capacity. Finally, they also envisioned in the long run, the creation of a single health care system divided by functions, and not by target population groups with a considerably larger participation of the private sector through, among others, the formation of new health management organizations (HMO).

The *Economía y Salud* proposal was successful in putting the health issue on the public agenda and in articulating the policy debate around the reform—with positions against and in favor of it.⁹² It also was successful in permeating the State's decision making on the health reform agenda. However, due to the fact that the technocratic faction in the economic team with which Funsalud had established a strong policy network lost the project to another *camarilla* and also due to its lack of concrete short-term strategies for implementing the proposal, it did not manage to participate with the technocratic team and thus had no control over the reform's resulting policy implementation plan.

In 1994, as the presidential elections got closer, the PRI invited Jaime Sepulveda's team, the *Economía y Salud* team, CEDESS, and Juan Ramon de la Fuente, director of the National University's Medicine Faculty, along with other public officials, to organise a group called *Grupo Asesor en Salud* and prepare a health *white paper* to be incorporated into PRI's political platform for

⁸⁹ FUNSALUD researchers had access to wide information sources from government organizations such as the Finance Ministry, the National Institute of Statistics (INEGI), IMSS, CEDESS, and ISSSTE.

⁹⁰ One of the elements on which employers and technocrats coincided regarded the relation between health and economy. That is to say, the relation between productive investment in equal, efficient, and good quality health services with the increase in human capital, productivity, and competitive capacity. Fundación Mexicana para la Salud, *Economía y Salud. Propuestas para el Avance del Sistema de Salud en México, Visión de Conjunto*, México: 1994

⁹¹ The National Development Plan (PND), the Health Sector Reform Program (PRSS) and IMSS' *Diagnostico*.

⁹² For instance, Funsalud's proposal was heavily criticized in an academic forum by the left wing Xochimilco University group as a neo-liberal project that took away from the State its responsibility to guarantee free and universal access to health care for the entire population.

the presidential campaign. This group worked for many months on a policy proposal⁹³ and competed to have control over its end result. It also strove to establish closer links with the technocratic faction of the economic team that was now in charge of the reform proposal, and was working on presidential candidate Zedillo's government plan in a parallel arena to that of PRI politics.

In spite of these efforts, the reform's content remained firmly under the control of the technocratic team. This group took Funsalud's input, as well as the white paper's, but did not establish a policy dialogue with any of the teams that had prepared them. Instead, it continued to conduct its own analysis of other country experiences in the field of health care reform and decided on the reform's content, scope, and timing in an isolated manner away from the public policy debate arena in which the other groups were operating.

In retrospective, what can be perceived are two different arenas where policy debate around the reform was taking place. The following diagram (Diagram 4g) shows, in the top track, the insulated policy arena where the different technocratic factions discussed and competed to control the health reform project away from the debate and competition that was taking place simultaneously in the somewhat more open—if still very exclusive—arena with the participation of social and other State groups – represented in the bottom track. While the overall aim was social security reform, the content of the proposal varied according to the arena on which it was discussed and negotiated. The grey areas show the moments in which the health aspect of the social security was discussed in both arenas. Given the political power of the economic team, the content of the resulting reform gravitated mostly around economic and financial issues, whereas the reform of the health component was only central to the more open arena involving State and social actors related to the social sector.

The reform agenda, the change of administration, and the 1994 economic crisis

Thus, under the control of the technocratic team, the reform of IMSS health services had two characteristics that relate them to the economic team's social sector reform agenda. First, it could be considered as an extension of the financial restructuring of IMSS insurance funds into the daily operative process of IMSS health services; and second, it followed the principles used by the technocratic team in social sector reform—rationalization of expenditures, focalization, and performance incentives among others. Also, as opposed to the pension reform, most of the policy changes related to the health component could be pursued through administrative acts and decrees internal to IMSS, without the need to amend the Social Security Law. This meant that there were few institutional requirements for consultation and the participation of interest groups in the field, and that its timing did not have to abide by the legislative calendar.

In the early stages of reform formulation, a certain balance persisted between the reform objectives related to pensions and those related to health services. These were the increase of internal savings through the privatization of the pensions system; stabilising of IMSS finances through the financial reengineering of the Institute's core insurance funds (pensions and the health component); and the expansion of and improvement in quality of IMSS health care services. It was clear that the aim was to carry out an integral reform; one that would imply the transformation of IMSS (the old actor in the health care system) and the creation of new actors, such as HMOs that would cater for IMSS affiliates who decided to take the opt-out and quota reimbursement option that was described above.

⁹³ See Grupo Asesor en Salud (SSA-SHCP-CEDESS-Funsalud-Grupo de Prospectiva), *Salud Para Todos los Mexicanos. Líneas Estratégicas para un Programa de Salud 1994-200*, noviembre 23 de 1994.

At the end of his mandate, President Salinas' economic cabinet presented the policy proposal prepared by CEDESS. Given the proximity of the change of administration, it was decided that further formulation and eventual implementation should take place during the incoming Zedillo administration. President-elect Zedillo asked Borrego to remain as IMSS director and to develop a political strategy to implement the reform (Interview, 05/5/99). Gabriel Martínez and his team had already started work at the Finance and Systems Division in IMSS with the political backing of the newly-appointed Finance Minister, Serra Puche.

The incorporation of Gabriel Martínez into IMSS was seen as a signal of the government's resolution to implement the social security reform. However, in spite of these preparations and the fact that the incoming government counted on a reform proposal which was virtually ready to be implemented, a series of political and economic events radically changed the country's conditions and with that, the possibility of an integral Social security reform.

The December 1994 economic crisis, which resulted from the current account deficit and the pressure this generated on the exchange rate, made the new government concentrate on one objective: to stabilise the economy. The urgency to undergo economic adjustment and to bring public finances back to equilibrium, reinforced the new economic team's perception of the need to restructure the pension system and to reorganise IMSS' finances. The IMSS directors shared this perception of the urgent need for reform and reorganization, since the decrease in quota collection as a result of the economic crisis were putting the Institute's finances under severe strain (Interview, 04/13/99).

The public's perception was that the depth of the 1994 crisis was largely due to the recently appointed Finance Minister Jaime Serra Puche's mishandling of it and he was made to resign less than a month after he had been appointed. However, he did manage to negotiate for his collaborators to remain in their posts in different ministries (Interview, 02/24/99). Thus Gabriel Martínez and his change team, though deprived of their most important vertical link in their network of support, remained in the IMSS and continued to pursue their reform agenda if under much more constrained circumstances.

As the reform agenda was being adjusted to the new circumstances, the restructuring of the pension system and the financial reorganization of the insurance funds were perceived as indispensable conditions for the institution's survival. But this was not the case with the reform of the health component of social security (Interview, 04/22/99). The decrease in the quota collection became in itself an obstacle for the implementation of the health component reform, due to the lack of resources to pay for the transition.

Thus, as an outcome of the December 1994 economic crisis, the reform of the social security pension scheme gained priority status on the public agenda, but the impetus for an integral reform that would pursue IMSS pension and health provision reform simultaneously, was lost. By early 1995, the Zedillo government had decided to concentrate its political and economic capital on the pension reform and the reorganization of the Institute's finances, and to leave the health component for a second stage. Nevertheless, there were several attempts at reincorporating the health reform in part or in its totality, and a few elements—notably those that did not require an open confrontation with IMSS bureaucracy and its union—did reach the implementation stage.

Negotiations within the Executive (1995)

The formal process of reform of the Social Security Law began with President Zedillo's speech in the LXXVI IMSS General Assembly, held the 25th of January, 1995. In his message, he summoned the Institute's community to carry out an assessment of the IMSS, and invited

different social groups, particularly workers and employers, to participate in the debate. However, given that at the moment this invitation was made, the government had brought the social security reform proposal to near completion, this exercise aimed more at complying with a formal exercise of policy dialogue, than with promoting real participation in policy decision making by the groups being addressed.

In March 1995, less than two months after the President had formally invited all groups to participate in the IMSS assessment, the IMSS directors presented the *Diagnóstico* document. The *Diagnóstico* document stemmed in fact from the *Proyecto Aguila*, which had been prepared by CEDESS in 1994. IMSS officials describe it as the “public relations” version of the IMSS reform contained in the *Proyecto Aguila* (Interview, 10/06/99). In simple direct terms, it stated the problems faced by each of the Social security funds and the administrative difficulties faced by the agency as a whole. It does it in a way that the *Proyecto Aguila* reform proposal would be seen as the plausible solution to these problems. Under these circumstances, when the *Diagnostico* document was made public, it was immediately rejected by the IMSS union on the grounds that it had not been invited to participate in its elaboration (Interview, 5/05/99).

As soon as IMSS' *Diagnóstico* became public, the Institute began to implement a series of political strategies directed to overcoming possible resistance and trying to avoid the formation of a coalition of resistance—probably around the IMSS union—as had happened a decade earlier. A media campaign was launched to inform public opinion about the IMSS situation and the need to carry out the reform. Information was guided to present the government's reform project as the best possible option, seeking the support of public opinion (Interview, 5/11/99). Simultaneously, negotiations were started with the business and corporate leaders, notably the CCE, and with representatives of the official labor sector movement for the same purpose.

The *Diagnóstico* did not develop proposals to solve the problems, but these were made public in another IMSS document, called *Hacia el Fortalecimiento y Modernización de la Seguridad Social*⁹⁴ presented in mid-1995. The comparison between this document, and 1994's *Proyecto Aguila*, clearly shows how the government's intent to reform the IMSS health component along with pensions, had dwindled. Health reform was reduced to little more than the re-formulation of the tripartite quotas for this insurance fund and the expansion of coverage through the creation of a Family Health Insurance (SSF) by which informal workers and their families could have access to health care through a voluntary and partly subsidized health insurance scheme. Notably, the controversial opt-out and quota reimbursement policy, which if applied systematically might have significantly transformed the IMSS, remained as part of the proposal – albeit without acknowledging the need to establish clear and non-discretionary regulations for that purpose.

During the same time that the *Diagnóstico* document was made public, the *Proyecto Águila* was presented to the new economic cabinet. The cabinet appointed pension and health committees, comprised of representatives from various ministries, such as Finance, Labor, and IMSS, to refine the reform proposals (Interview, 05/11/99). The points of dissension were negotiated in the following months within the cabinet's technical committees away from public scrutiny. For instance, in relation to the pension scheme, while the Finance Ministry economists were in favor of letting each worker choose his/her own pension fund, the Institute representatives favored the option of having either the union or the employer chose it for them (Madrid, 1998). Also, there were lengthy deliberations about the optimal share of employer and

⁹⁴ IMSS, *Hacia el Fortalecimiento y Modernización de la Seguridad Social*, 1995.

employee social security contributions,⁹⁵ and that of government.⁹⁶

It was during this period of reform formulation and negotiation within the closed arena of the Executive power that a deliberate decision was taken to exclude any element concerning the restructuring of the health component of Social security. The Law initiative would include only the changes to the pension system and the financing regime of the funds. The health care reform was abandoned at that moment because it was thought that including additional elements in the Law initiative would burden the policy agenda, and the political feasibility of the priority reforms would be put in jeopardy (Interview, 04/13/99). Thus, without the direct pressure from groups against the IMSS health reform, the economic change team chose to discard it and not to saturate the policy agenda.

The possibility of implementing the health care reform through modifications to internal rules and regulations, without changing the Law, played a major role in that decision (Interview, 04/16/99). It was thought possible to move the reform process from a legislative arena that was open to the influence of many actors, to an IMSS internal arena, where the process was exposed to the influence of fewer actors, in spite of the fact that the union's influence increased.

The final reform package for the IMSS health component included the following elements:

1. Financial restructuring
2. Deconcentration and rationalization of the IMSS
3. Institutional model for comprehensive health services (MIAIS)
4. Medical areas for deconcentrated management (AMGD)
5. Family health insurance (SSF)
6. Family doctor eligibility and performance incentives in family health care centers
7. Performance incentives
8. Costing according to diagnosis-related groups (DRGs)
9. Contracting-out of health services

It can be argued that six out of the nine reform components are related to the rationalization of resource management for the sake of a more efficient use of the latter. At the same time, many of these policy proposals were linked with the Zedillo administration's health reform program (PRSS). Notably, this includes the creation of the Family Health Insurance, aimed at expanding the social security's health component's coverage through a health insurance

⁹⁵ Enrique Dávila, then chief of staff of the Finance under-secretary, and Carlos Noriega, chief of staff of the Finance minister, lobbied in favor of a fixed quota to finance the Illness and Maternity fund. The Labor Ministry's lawyers opposed this, arguing that it contradicted the constitutional principle of equity and redistribution. Finally, they agreed upon a fixed government and employer contribution for employees with salaries below three minimum wages; plus a worker/employer's contribution as percentage of the base salary, paid on salaries above three minimum wages (Interview, 04/16/99).

⁹⁶ An increase in the government's quota share was perceived by several of the policy makers in charge of the reform as an essential condition to implement the proposed fixed quota financing scheme for the Illness and Maternity insurance, and at the same time achieve the fund's financial equilibrium. Therefore, several officials of the Ministry of Finance lobbied the Minister in favor of these measures, and got him to accept them (Interview, 04/16/99).

scheme for workers in the informal economy. The other element that ran along the lines of the health reform program was the creation of the AMGDs, since it was a decentralization effort parallel to that of the Ministry of Health services.

The reform initiative related to the systematic application of the opt-out option that would have triggered the transformation of IMSS and given the incentives for the creation of the new actors in the sector – the HMOs - was not included in the reform package, but remained present as part of the Social Security Law initiative that was presented to Congress.

Opening the process? A forum for consultation (late 1995).

Once the reform's content was agreed upon within the Executive in the cabinet's technical commissions, labor and business leaders, together with public officials were invited to participate in a forum to discuss the reform. This was part of the formal reform process called *Comisión Tripartita para el fortalecimiento del Instituto Mexicano del Seguro Social*.

The formal objectives of the seven technical commissions integrated within this forum were to analyse the problems of each of the IMSS insurance funds, and to present policy proposals. Nevertheless, there was a tendency to direct the reform content to what had already been decided within the Executive (Interview, 04/15/99). On November 1995, the *Comisión Tripartita* presented to President Zedillo its final document called the *Propuesta Obrero-Empresarial de Alianza para el Fortalecimiento de la Seguridad Social*.⁹⁷

Although it was a joint labor-business-government document, the proposal clearly reflected the government's policy priorities. For instance, as a result of its deliberations, the tripartite technical commission articulated the following fundamental goals: to reach universal coverage; to attain financial self-sufficiency; and to improve the quality, efficiency, and satisfaction of service provision. The concrete measures to improve the quality of the service were: doctor eligibility, capitation, and permanence and productivity incentives.⁹⁸ It also recommended an increase in the government's quota share and the systematic implementation of the opt-out and quota reimbursement mechanism.

The formulation of the reform proposal was formally attributed to the *Comisión Tripartita*,⁹⁹ but its capacity to influence the reform agenda was practically null. More than a real negotiation and consensus building, it was an exercise with which the government fulfilled, in a formal way, the requirements for the sectors' participation in the process. The intention was to present the document as a labor-employers' proposal to weaken possible SNTSS' arguments against the reform, when in reality it had been previously negotiated, even with the CTM and the CCE (Interview, 05/5/99).

Once the president gave his approval to the reform proposal, the process was opened to participation of a wider group of actors. Negotiations within the Executive halted and lobbying started within the Congress (Interview, 05/5/99).

⁹⁷ Presentación al C. presidente de la República, Ernesto Zedillo Ponce de León, de la propuesta Obrero-empresarial de Alianza para el Fortalecimiento y Modernización de la Seguridad Social, 1^o de noviembre de 1995.

⁹⁸ These measures were intended to generate quasi-market mechanisms and competition as incentives for medical personnel to improve quality of services.

⁹⁹ In the speech following the presentation of the labor-employer's alliance propositions, President Zedillo committed the government to "respond" to their proposals.

LEGISLATION (NOVEMBER/DECEMBER 1995)

The IMSS director, Genaro Borrego, who had been given the task of negotiating the Executive's reform initiative with labor, business, and the IMSS union, was again commissioned to lobby for it in Congress. It was his political brokerage experience as a former PRI president, former governor, and former PRI Senator that gave political feasibility to the technocratic reform proposal prepared within the Executive. In the Legislative arena, the SNTSS, the main actor lobbying against the reform proposal, was able to exert a significant degree of veto power through its influence on legislators unwilling to be at odds with organized labor. But this proved to be insufficient to veto the pension reform, which was a priority for the Executive.

On November 9, 1995, President Zedillo presented the initiative for the New Social Security Law before Congress. The reform proposal for the pension system that appeared in the initiative is very similar to the one formulated in 1994 in *Proyecto Águila*. The health component reform initiative had been significantly reduced, but still contained the modifications in the tripartite quota contributions that would bring fresh resources to the Institute and the creation of the Family Health Insurance. However, the reform initiatives contained in the joint tripartite proposal¹⁰⁰ and the *Proyecto Águila*, that required the modification of the IMSS collective labor contract, or had the potential to have an impact on labor conditions, were dropped from the agenda. Such was the case of the doctor eligibility initiative and the modification of doctor's payment to introduce incentives to permanence and productivity and eventually, capitation. At this stage, the reform initiative still contained the Law amendment for the more systematic implementation of the opt-out policy.

The limited nature, both in number and scope, of the proposals geared at reforming the IMSS health component that were incorporated to the Law initiative before it was presented in Congress, leads one to conclude that the idea of an integral IMSS reform was abandoned even before it was formally submitted for legislation. Following lobbying and negotiations in Congress prior to the reform initiative's formal presentation, the IMSS directors were led to conclude (and therefore to warn the economic team) that if the health component was included in the Law initiative, it would not be approved in the Legislature (Interview, 04/13/99). So given that the central objective of the economic team and the President's was to ensure the approval of the modifications to the pension system and the Institute's financial regime, the initiative was divested of the health component issues mentioned above.

Indeed, the relative importance of each of the reform's components, and thus the probability that it would be included in the Law initiative, can be traced back to which actors supported it, and to what extent. In the case of the pension reform, it was clear to all actors that the President was committed to it, and that to oppose this initiative would have been politically very costly (Interview, 04/16/99).

In the case of the reorganization of the IMSS financing scheme, the thrust of the support came from the Finance minister and one of his under-secretaries (Interview, 04/16/99). This was decisive for its inclusion in the new Law.

¹⁰⁰ *Hacia el Fortalecimiento y Modernización de la Seguridad Social* (1995).

Concerning the health component, no one clearly supported its inclusion in the Law initiative. On one hand, neither the Office of the President, nor the Finance Ministry was committed to it. On the other hand, the IMSS directors perceived that they did not have sufficient political capital, and enough economic resources to promote it on their own.¹⁰¹ Likewise, the IMSS directors considered that the restructuring of health service provision could be implemented at the administrative level, through the modification of regulations, without the need for Law amendments (Interview, 05/11/99) (Diagram 6).

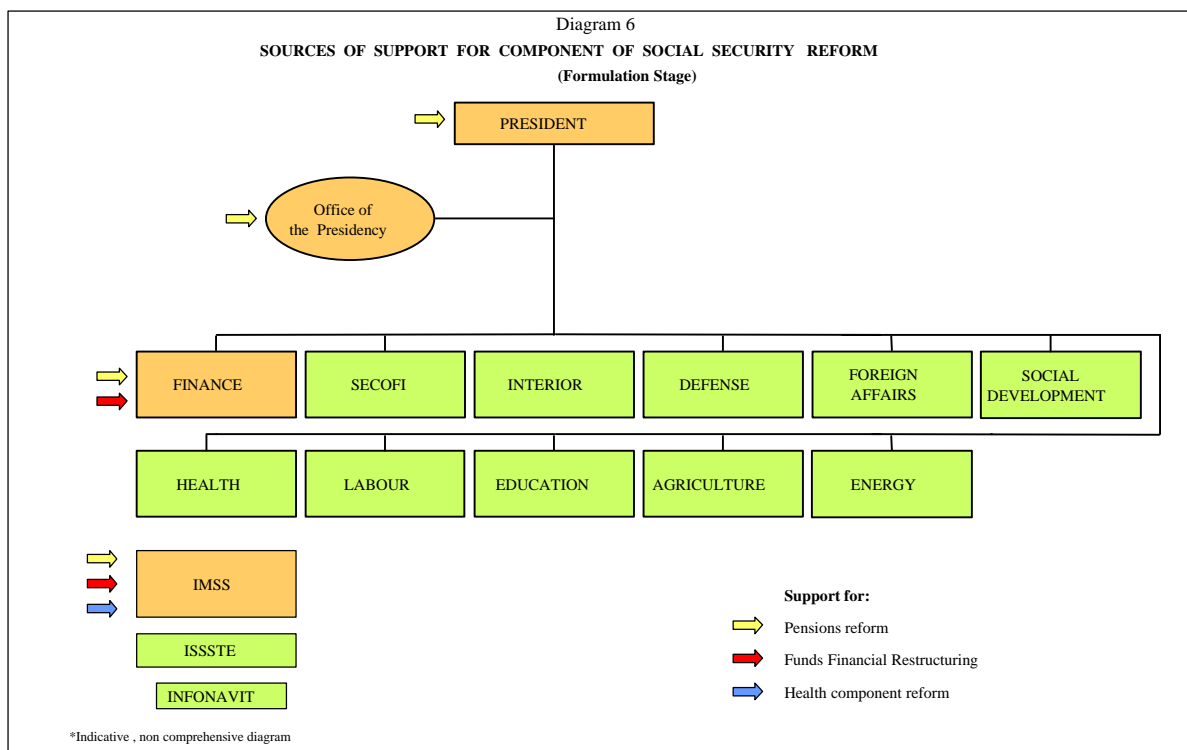

Finally, the incentives for the Institute's directors to reform the health component diminished once IMSS' financial short-term problems were solved as a result of the fresh public resources mandated in the new Law. With the pension system's restructuring and the reorganization of the health component's financing scheme, the reform of the health component was not perceived as urgent anymore (Interview, 05/11/99). Diagram 7 shows that the Illness and Maternity Fund solved its deficit problems as of 1997, when fresh funds were introduced. However, expenses continue the same trend, reflecting no significant impact of any cost containment measures.

APPROVAL IN CONGRESS

Before the reform project had been sent to the Lower House, the IMSS director, Borrego, who had been in charge of brokering the reform, felt resistance from various opposition legislators. The opposition even included some PRI legislators, who still resented having been forced to vote in favor of the Executive's highly unpopular proposal to increase the Valued Added Tax by 50%, and were thus reluctant to vote in favor of it (Interview, 05/5/99 b).

¹⁰¹ To push the health reform forward, it would have been necessary for the President or a Secretary of State to support it, and no one did (Interview, 16/IV/99).

With this perspective in mind, the IMSS directive implemented a political strategy to obtain the project's approval in Congress. Alongside its media campaign to inform public opinion and generate social support around the reform proposal, it lobbied in favor of the project among key interest groups, such as labor unions, pensioner's organizations, and the business community. Some government officials think that the IMSS directors might have recommended including the opt-out and quota reimbursement initiative in the Law. This would have been less a matter of reforming the IMSS—if approved, but simply to serve as a bargaining chip to be used during negotiations in Congress (Interview, 05/5/99 b).¹⁰²

Diagram 7
Balance of the Illness and Maternity Branch

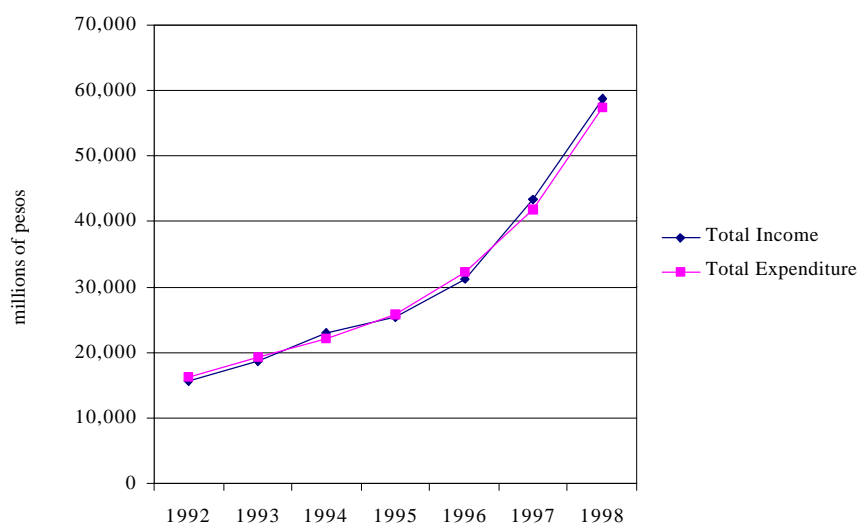

Source: IMSS

At the same time, the IMSS directors sought to establish personal contact with PRI representatives to explain the reform's content and try to convince the dissidents and the indecisive. In coordination with the IMSS directors, a number of political operators lobbied in favor of the project within the PRI's legislative fraction. Among them, the president of the Congress' High Commission (*Gran Comisión*) and one PRI member with political power within each

¹⁰² And indeed this was an element that generated great resistance from the SNTSS, but was not crucial for the Executive's project, so it could "yield" to the union's pressure. During the bargaining process in Congress for the approval of the new Social Security Law initiative, this amendment was dropped by the Executive when legislators, concerned with the IMSS union reaction, conditioned their vote of approval of the entire new Law on the elimination of this amendment. Also, given that the pension reform required a large amount of political capital, the technocratic team decided to diminish the number of points of confrontation with the largest union in the country. The he Social Security Law, as it stood, allowed albeit in a very vague manner for the opt-out option as well as for the contracting-out of health services. Reformers decided to pursue these issues through new regulation and administrative acts, thus avoiding the further politicization of the issues.

of the party's sectors. Due to internal party alliances and bargaining calculations around policy issues—plus the fact that their interest were not at stake—the National Peasants Confederation did not present major resistance to IMSS reform. However, CNOP members, and specially CTM members, presented a major challenge.

Legislators who belonged to PRI's labor sector manifested strong resistance to the reform project. This was especially true for representatives with links to labor unions. Alejandro Audry, a PRI congressman and Political Action Secretary of IMSS union, was one of the most fierce and vocal opponents of the reform.¹⁰³ The lobbying among congressmen included pork-barrel strategies in the form of perks and benefits to individual congressmen (Interview, 05/5/99b). The President himself participated in lobbying the National Action Party by holding conversations with PAN's president. The PRD, however, manifested its unconditional intention to vote against the project from the start.

In spite of this intensive lobbying activity, the Executive's project for social security reform faced such opposition in Congress,¹⁰⁴ that only the PRI's legislative majority - which still prevailed in 1995 in both Houses, granted a fast approval, with no substantial modifications, of the New Social Security Law initiative. In spite of their disagreement with the reform proposals, PRI members abided by party discipline.

Two of the left wing opposition parties, the Party of the Democratic Revolution (PRD) and the Labor Party (PT) opposed the reform on ideological grounds. The National Action Party's position was more ambivalent. On the one hand, privatization of the pension system was in accordance with the party's principles; on the other, PAN legislators were preoccupied with the political costs of their support for the Law's approval (Madrid, 1998). PAN representatives voted within the party to define the party's position regarding the reform proposal. In spite of the national party leader's lobbying effort, only 18 congressmen voted in favor of the reform, 54 voted against it, and 19 abstained. Some political observers think that PAN representatives received instructions to vote against the initiative to further undermine political support for the PRI (Interview, 8/4/99).

Although the Law initiative's final version contained more than 60 modifications, it essentially maintained its original orientation. As was expected, the most significant modification was the retrieval of Law amendment stating the conditions and requirements to sanction opt-out agreements in a non-discretionary manner.¹⁰⁵

The initiative for the New Social Security Law was approved in the Lower House on December 7, 1995 with 289 PRI votes in favor and 160 votes against it. A few days later, it was sanctioned in the Senate with no modifications on December 12, 1995. The following diagram shows the position of the different groups that were involved in the approval of the Social Security Law, as well as their level of influence (Diagram 8).

¹⁰³ Audry voted against the first version of the reform proposal, but yielded at the end changing his vote.

¹⁰⁴ Resistance to the reform was so strong, that sacrifice of the financial restructuring of the insurance funds was considered, so the reform of the pension system could be sanctioned (Interview, 04/19/99).

¹⁰⁵ The IMSS union's intent was to eliminate the article in the Law that currently grants the possibility of quota reimbursement altogether. However, after the New Law's approval, the article remained the same as it was in the original Law – with the exception of modifications to the procedure to obtain quota reimbursement.

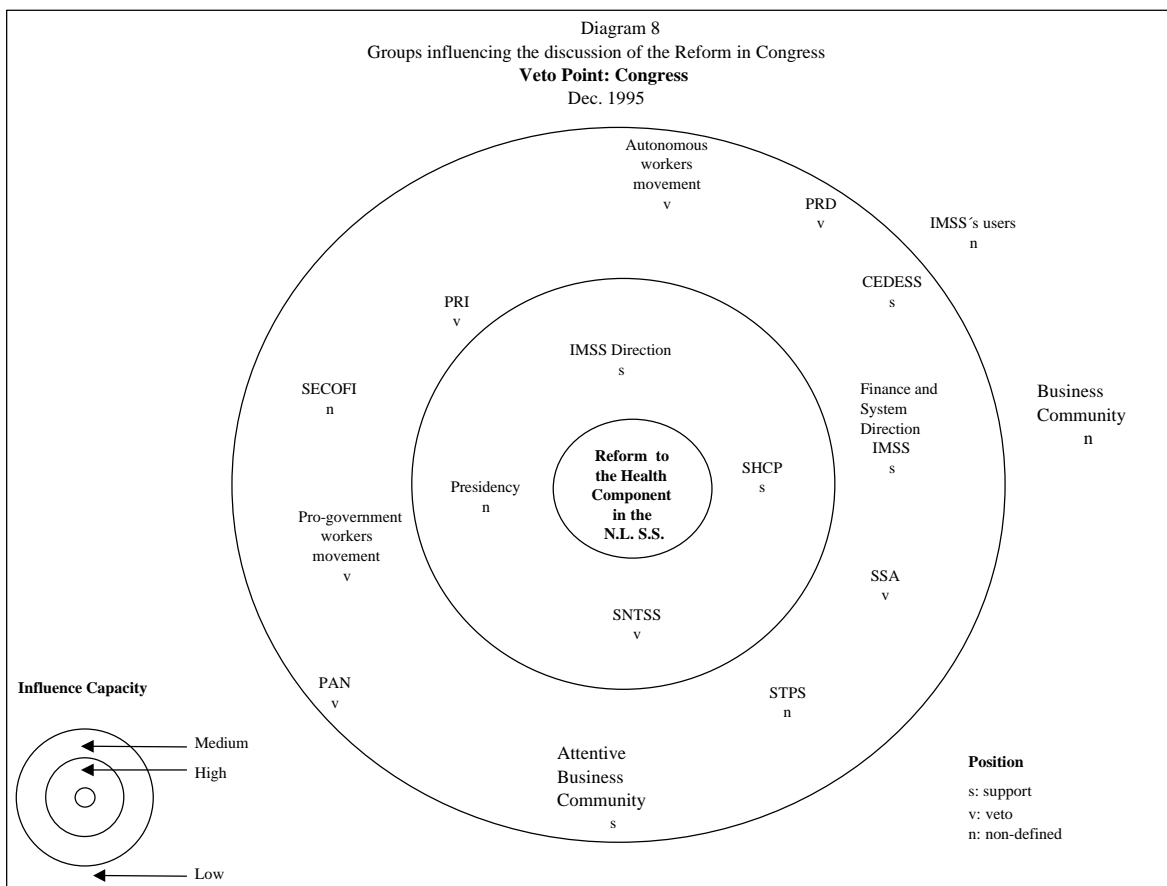

IMPLEMENTATION (1996 – 1998)

After the new Social Security Law was approved in Congress in 1995, the pensions reform implementation was started right away. A transitory article mandated the rest of the reform – i.e. the health component - to start implementation in 1997, to allow the Institute to prepare for policy change. Thus the reform process gravitated back to the IMSS arena, where the reform package for the health component of social security was being formulated.

The technocratic team in IMSS working in the Finance and Systems Department under the leadership of Gabriel Martinez, continued to work closely with its counterparts in the Finance Ministry, who were in charge of reforming the social sector. Now, however, they were working from a position of weakness given Serra Puche's resignation as Finance Minister back in 1994. The change team was forced to negotiate and look for consensus with the other groups within IMSS, noticeably with the SNTSS, in order to implement its policy change initiatives. Moreover, because the health reform was not a priority in the Executive's agenda, and a potential labor conflict within the Institute is always a serious matter for concern – due to its immediate visibility, the IMSS directors's support for the reform initiative was less than whole-hearted.

The principal obstacle within IMSS that any reform initiative faces is the SNTSS' resistance to change (Interview, 05/5/99), and the union had regained its position of power as soon as the new Law was approved and the reform entered its implementation stage. The SNTSS is the second largest union in Mexico, with 350,000 members. Practically all IMSS personnel are affiliated with

the union,¹⁰⁶ leaving little room for maneuver to the Institute's directors. Since the repression of the medical movement in the mid-sixties, the possibilities for the doctors to organize as an interest group was constricted, and the only channel for collective action open to them was the IMSS union. Therefore, the IMSS union counts on doctors and nurses as well as administrative and maintenance personnel.

The union's political strength is based on a series of factors, including the size of its membership. The average education level of its members, especially doctors, allows for the development of an agenda of its own and sophisticated policy proposals. The union has contacts with other political forces with high mobilization capacity, like left wing parties and guerrilla movements.¹⁰⁷ Finally, it has a presence at the national level as service purveyors and its daily contact with the population allows it to generate a base of support loosely tied to that of the government.

On the other hand, due to the size of the union and its members' heterogeneity, it is very difficult for the leaders to maintain control over all its sections. It has happened on several occasions that the unions' membership gets mobilized and the leadership is disowned. In 1990, just after a conflict with the Institute's directors over the review of the collective labor contract, a dissident faction took control of the union's leadership. The new leaders, with a work agenda of their own, confronted the IMSS directors with greater strength. Currently, their main objective is to avoid, or in any case minimize, the negative impact of IMSS reform on the union's interests. It is particularly concerned with the possibility of the full or partial privatization of the IMSS and possible personnel cutbacks (Interview, 04/21/99).

Furthermore, the SNTSS has joined the independent labor movement that, since the early nineties, intends to establish its independence from the government and the rest of the official organized labor movement. This has been an important element for consideration in the government's policy decision making. In this context, the support offered by the IMSS directors for any reform proposal depends on its assessment of the political costs and benefits of backing a policy initiative. Without the President's political backing or the support of the core ministries, the IMSS finds itself alone *vis a vis* a union with high mobilization capacity, that has shown its willingness to exercise collective action in defence of its interests, thus raising the political costs of an open confrontation.

ANOTHER ATTEMPT AT HEALTH REFORM

The opt-out and quota reimbursement initiative—the most controversial policy proposal in the IMSS health component—stands as a case in point. After the economic team's decision not to present it as part of a Law amendment in Congress, political support was going to come from outside IMSS. An *ad hoc* inter-agency group similar to the cabinet technical commissions was put together within the Executive in 1996 to study the need to regulate the private health sector and

¹⁰⁶ When one of them is appointed for an important position within the organization, he has to ask for a temporary leave authorization from the union. So, although formally he is considered a middle level employee, his loyalty stays with the union and he rarely opposes it.

¹⁰⁷ The IMSS union has strong representation in some of its sections of left-wing opposition parties, particularly the PRD, as well as confrontational political groups with close ties to EZLN in Chiapas. A brother of Miguel Angel Saenz, the union's leader for eight years before Antonio Rosado, belongs to the National Liberation Front, a guerilla movement. Margil Yáñez, second in rank to Sáenz and a member of the SNTSS leadership is the brother of German Yáñez, the military strategist of EZLN in Chiapas. It is not surprising then that left wing ideologies and strong opposition to the neo-liberal agenda are preeminent within the SNTSS.

the emerging Health Management Organizations (HMO) market. Because the initiative was intrinsically related to the opt-out issue,¹⁰⁸ the long standing discussion about the possibility of establishing a more systematic opt-out option mechanism for IMSS affiliates was renewed within the economic team in the Executive.

This inter-agency group formed by officials from the President's Office, the Finance Ministry, the Health Ministry, and the IMSS started to work on a policy proposal to regulate both the IMSS opt-out policy, and the Health Management Organizations (HMO) emerging market. This would have triggered the reform of IMSS, as the old actor in the sector, while simultaneously creating new actors in the sector that would be prepared to assume part of IMSS' responsibilities. But, once again, the possibility of a confrontation with IMSS' union, and its political consequences, led the group to postpone the former and to carry on exclusively with the latter. Political considerations were not the only concern this group had when it decided to postpone the issue once more. The other reason behind not pursuing this line of policy change was the lack of documented proof that the implementation of the opt-out option and quota-reimbursement scheme was going to have a positive impact on the health system as a whole – or that of IMSS' affiliates (Interview, 05/11/99).

Furthermore, given that the new Social Security Law had augmented the government's participation in IMSS funding, the group of businessmen who had been lobbying to have the opt-out policy implemented failed to present convincing evidence on the financial soundness of quota reimbursement. This was true for both parties—IMSS and the businesses.¹⁰⁹ Also, the economic team was aware that the private health sector was not prepared to absorb a sudden increase in health services demand, since with few exceptions it is concentrated in the major urban centers. It continues to be a very desegregated market with very small unregulated providers scattered unevenly throughout the country (Interview, 05/11/99).

As a result, when the reform initiative to create and regulate the new HMOs was ready, the inter-agency group decided to introduce a Law amendment separate from the social security legislation, and instead sought to modify the General Law of Mutualist Insurance Societies and Institutions. The decree to reform the Law was presented to the Lower House on April 1999. It stated that changes were needed in order to establish a regulatory body for the medical pre-paid market that had operated in an anarchic way during the last few years.¹¹⁰ The decree initiative was approved in the Lower House with the favorable vote of all the political parties, and was sanctioned by the Senate in November 1999.

Policy makers involved in the reform initiative expect that with the regulation of the health business market, investors would be given certainty, and thus there would be a significant increase in private health infrastructure. This development would then contribute to solve what has been a *de facto* obstacle for the opt-out and quota reimbursement policy implementation.

¹⁰⁸ Since investors in the HMO market are interested in catering to IMSS affiliates who would look for services in the private sector if the opt-out option were to be applied.

¹⁰⁹ The new Social Security Law has significantly diminished the quota amount required from the business sector by augmenting that of the government. This fact not only diminished the business sector's urgency for quota reimbursement, but strained the feasibility of paying for similar services to private providers with the reimbursement of the new quota.

¹¹⁰ The fundamental goals for the regulation of the HMOs' operation are to promote market development, give certainty for investment, and guide and protect the consumer. "Exposición de motivos a la "Iniciativa de Reformas a La Ley General de Instituciones y Sociedades Mutualistas de Seguros".

Finally, a better developed and more regulated private health provision market would create incentives for current IMSS affiliates with purchasing capacity – and particularly their employers – to press for the opt-out policy to be applied (Interview 10/10/99).

If this happens, in the long run, it would be conducive to IMSS' downsizing and effective reform.¹¹¹ Thus the health system would be significantly transformed in the direction envisioned by the economic team in the official health reform proposals—both sector wide, and for IMSS—without the need for direct political confrontation with the IMSS union. This scenario shows that the technocratic team at present eschewed short-term comprehensive and State-directed change, for gradual in the long-run change brought about by market incentives. Both the creation of the new actors in the sector (i.e., the HMOs), and IMSS integral reform are therefore only in the making.

CLOSING REMARKS: KEY POLICY NODES AND ACTORS

As the Zedillo administration is coming to an end, the IMSS financial restructuring is well on its way. The significant increase in the government's quota participation—a result of the new 1995 Social Security Law—restored IMSS actuarial equilibrium. The change team within IMSS, now heading the Finance and Systems Department, managed to complete the financial reengineering of IMSS' insurance funds—with the exception of pensions, which have been privatized. This eliminated cross-subsidies among them and made resource allocation more transparent. The Family Health Insurance scheme has been operating since 1997 and has affiliated 300,000 families, but it still needs to expand more aggressively if it is to meet the government's stated goal of increasing access to IMSS health services to all families with purchasing power who work in the informal sector. All the other policy changes in the IMSS health reform package (i.e. the integral model of health services delivery, AMDGs, family doctor eligibility, the use of performance incentives, DRGs and contracting out services) are still in the pilot phase under the close scrutiny of IMSS union leaders. The opt-out and quota reimbursement policy has largely been left untouched.¹¹²

The analysis of the social security reform process, including its health component, brings to light three major veto points. The main veto point was located within the Executive, during the period of policy formulation. All external actors, including the SNTSS, and to a great extent, the IMSS directors proper, were excluded from this arena and precluded from participating in the decision-making process. The veto point located in the Executive, where factions from the economic team stemming from the core ministries battled to influence it, was crucial to the reform of the IMSS health component. This was where that it was decided to approach the reform through regulation and administrative actions, rather than resorting to the amendment of the Social Security Law.

The second veto point was located in Congress, specifically in the Lower House, during the process of approval of the new Law. In this case, PRI legislators vetoed the amendment that

¹¹¹ Some people think that a mass exit of IMSS users towards private health purveyors is highly improbable, basically due to the cost differential between public and private institutions. On the other hand, there are elements that would favor the choice for private providers, such as reduced waiting time, quality of service, and status. Therefore, the outcome of the opt-out if it were applied, remains unclear.

¹¹² Interestingly, there are contradictory explanations from both State and society actors as to why its implementation did not go ahead. While some contend that the regulatory body needed to implement this policy is ready, but there was no political will to put it in practice; others contend that the technical complexity behind it is such, that the regulatory body is yet to be made operational.

sought to make a more systematic use of the opt-out option as a condition to vote in favor of the pension system reform and the financial reorganization of the other insurance funds and benefits. The IMSS union that opposed the modification of the article that regulates the opt-out option because it perceived it as a dangerous precedent for the privatization of the Institute, exerted pressure on legislators from different parties in order to have them veto the proposal.

Although the IMSS union cannot have direct participation in the legislative process, PRI and PRD legislators take into consideration the union's opinion when deciding their vote. As one PRI legislator put it, "PRI representatives do not like to vote against labor unions" (Interview, 05/5/99). Thus, perceiving the political costs of voting for an unpopular initiative, they constituted themselves in veto groups and voted against it. PAN legislators, although initially and ideologically in favor, voted against the Law's approval after earlier suggesting many modifications to the Law initiative,

Finally, the third veto point was located within the IMSS during the implementation period. In this arena, the SNTSS constituted the principal veto group. The strength of the union is enough to control and in some cases block the change team's reform proposals. The change team, with no firm support from stronger factions in government—particularly from the President and the economic team—needed to negotiate any undertaking regarding policy change implementation. This has affected the speed and scope of the reform process and makes the implementation of an integral health reform very difficult.

In view of this political stalemate, any potential for an in-depth reform of IMSS health service provision remains rather unclear and in the far future. Reformers foresee that a consolidated private health provision market—following recent Law amendments—would set in motion political pressure to implement the opt-out option, and thus reform IMSS.

III. CHANGE TEAMS AND OTHER POLITICAL STRATEGIES

This chapter analyzes the characteristics and policy strategies of the groups involved in the reform process of the health component of social security in Mexico. It describes the configuration, location, expertise, and previous policy experience of the set of groups that analyzed policy options for the health reform and sought to influence decision making around it by preparing alternative reform projects.

The analysis is based on the assumption that a change team is created as a strategy in and of itself, to bring about policy reform.¹¹³ The political economy literature defines a change team as a small group of technocrats isolated from other groups in the political arena and whose capacity to operate and pursue policy change depends on the support of a high ranking public official (Waterbury, 1992). Change team members share a common view on policy priorities, and a similar ideology with regard to the role of the State and the market in public policy.

While many groups aspired to lead the reform process by becoming its change team, not all of them were able to convene the skills and networks needed to become one. Each group's relation to the powerful economic team in the core ministries—Finance, Commerce, the Office of the President, and the Central Bank—proved decisive in determining their access to decision making and, thereafter, to being empowered to confront resistance to change from other groups.

Because the creation of a change team is itself a political strategy geared at pursuing a reform agenda, besides describing the characteristics of each group, the chapter discusses the formation of each group as a strategy to try to influence the reform process. It also examines some of the choices on political strategies the individual groups considered, such as insulation vs. consensus building or incremental vs. comprehensive policy change, in their attempts to enhance the political feasibility of their reform proposals. Finally, using the experience of the attempt at reforming the IMSS health care services, the chapter evaluates the pertinence of using change teams as a strategy to promote comprehensive reforms in public health care provision.

THE ECONOMIC CHANGE TEAM

Economic reform in Mexico was promoted during the eighties and nineties by a small group of technocrats whose careers were based at the financial and economic government agencies, defined here as core ministries. The key members of the technocratic group—in power since 1988—are Carlos Salinas, who was Planning Minister under Miguel de la Madrid, and then President of Mexico (1988 – 1994); Pedro Aspe, who was Finance Minister during the last year of De la Madrid's government and during the Salinas administration; José Cordoba, who was Chief of Staff under Salinas; Jaime Serra, who was Commerce minister from 1988 to 1994 and Finance minister during the first three weeks of Zedillo's administration; Ernesto Zedillo, who was Planning Minister from 1988 to 1992, Education Minister from 1992 to 1994, and President of Mexico (1994 – 2000); Luis Tellez, who was Agriculture under-secretary during the Carlos Salinas administration, Chief of Staff in the Zedillo government from 1994 to 1997, and Energy Minister since 1997; and Guillermo Ortiz, who was Finance Minister from 1995 to 1998 and currently heads the Central Bank.

¹¹³ Waterbury describes them as "efficient instruments government leaders may use to promote socio-economic reforms" (Waterbury, 1992: 192).

This team had ideological and programmatic cohesiveness. Its members shared a high level of technical education and a commitment to the principles of economic liberalism. However, given Mexico's informal rules to designate the presidential candidate for the incoming administration,¹¹⁴ this cohesiveness in ideology and policy content was not reflected in the political maneuvering of the team's members, since several of them aspired to the presidency. Thus, at least two factions or *camarillas* can be distinguished within the economic team, that competed for political power. The competition centered on the control and development of the strategic projects that were assigned by the President or his close aids, and by the number and nature of the government positions each faction could win for its members. These dynamics left their imprint on the social security reform process from its outset, since the economic team's factions competed for the control of the project.

The Ministry of Finance as a promoter of the Social Security reform

The first technocratic faction, based at the Ministry of Finance and the Central Bank, developed a project during the early nineties to privatize the retirement pensions system. For this and other reform projects, Finance minister Aspe had created a change team with very young and highly trained economists, mathematicians, and actuaries, who shared a neo-liberal ideology and had as their main goal, the reform of the State (Waterbury, 1992). Team members were isolated from the rest of the bureaucracy in both agencies, and from other interest groups, so as to avoid any possible external pressure on the project's formulation.

The group had broad horizontal networks of support with other technocrats in various government agencies, who shared the same vision of the role of the State *vis-a-vis* the economy and State-society relations. But their most important vertical network of support stemmed from the Finance Minister. With the economic reforms consolidated, Aspe had now turned the agency's efforts into implementing second-generation reforms (i.e., social sector reforms). The rationale behind this agenda was the impending negative impact on the public finances that an inefficient and financially unbalanced social sector could have.

The Finance minister and important members of his team had been directly involved in the economic reform of the eighties and nineties. Under the premise that all sectors could be reformed following a similar strategy, they envisioned applying the policy strategy that had been successfully used in the first generation reforms in which they had participated. Thus, as was the case during economic liberalization, the team sought to modify the structure of rules and incentives relevant to the pension scheme, and trigger policy change by letting the actors in the social security sector respond to the new rules of the game.

Their first project related to social security was implemented in 1992 in the form of the *Sistema de Ahorro para el Retiro* (SAR). However, since the team felt this reform was incomplete as it had failed to fully privatize the pension scheme, it set about to work on a more comprehensive reform project still under the leadership of the Finance minister.

The members of the Ministry of Finance/Bank of Mexico team shared a vision of the type of pension reform to be carried out. In accordance with the tenets of economic liberalism, the group's objective was to develop and implement a fully funded pension system with individual accounts. This would give rise, in their opinion, to a scheme with a better structure of incentives, and at the same time, would reduce the financial risk that the pension system presented to the

¹¹⁴ Under this system, for the last 70 years the President in turn names his successor from a member of the Cabinet at his discretion.

public sector's finances. The mechanisms they resorted to in their reform proposal were privatization, market competition, and eligibility of service purveyors.

The project leaders were the same ones who had led the SAR project, with the support and under the supervision of the Minister of Finance. They brought with them their previous experience in policy reform; specifically, the first attempt at pension reform. This previous experience would influence the content of their new reform proposal, as well as their strategies to implement it.

Because of its size and impact on the economy, Aspe perceived an urgency to start social sector reforms with the restructuring of the pension system. Although the team was aware of the need to restructure the health care component of the social security system as well, they considered it only marginally.

During the development of their reform proposal, and through personal contacts with the business community, the Finance/Central Bank team established an informal policy network with the like-minded private think tank, Funsalud. Aspe's team would provide information relevant to Funsalud's research project in return for the think tank's knowledge and expertise on social security matters, particularly in the area of health care provision. This informal relation, though, did not mean that the technocratic team granted Funsalud any possibility to influence the decision making process. The Finance Minister's team was aware of the need to reform the IMSS health services, and was thus interested in establishing contacts with other groups in and outside the State working on the issue. Nevertheless, the team was not considering the implementation of the health reform alongside its pension reform project.

A political struggle between the two rival *camarillas* within the economic team led to a takeover of the pension project by the faction led by the Office of the Presidency, and the Finance-Central Bank team was forced to abandon the project by mid-1993. The Under-Secretary of Finance, who belonged to the faction led by the President's chief of staff, assumed control of the project, and designated his chief of staff as project leader (See Diagram 9).

Two alternative explanations for this takeover have been put forth. On the one hand, the substitution of the Finance minister for a Finance Under-Secretary of the same institution, but with a close link to the President's chief of staff, may have aimed at establishing a more direct link between the pension reform project and the President, thus helping to insulate it from the internal political struggle surrounding the presidential succession (Interview, 8/04/99). The takeover could also have been aimed at establishing a clearer line of control between the President and the new change team, regarding the reform's content. On the other hand, the replacement of *camarillas* within the economic team might have responded to internal competition in view of the presidential succession, in which the *camarilla* of the President's chief of staff responded to pressure by government factions unhappy with the slow pace of the Finance minister's team in implementing the SAR, as an opportunity for a takeover (Interview, 16/04/99).

The new change team responsible for developing the pension project had a broad set of horizontal and vertical networks of support as well. Its key vertical links were with the President's chief of staff and the Commerce Minister. One of its horizontal ties was with the head of the Deregulation Unit at the Commerce Ministry, Santiago Levy, who was to become one of the Finance Under-Secretaries in the following administration in charge of the social sector. During the Zedillo administration, many members of this team's horizontal networks were to occupy key positions in government.

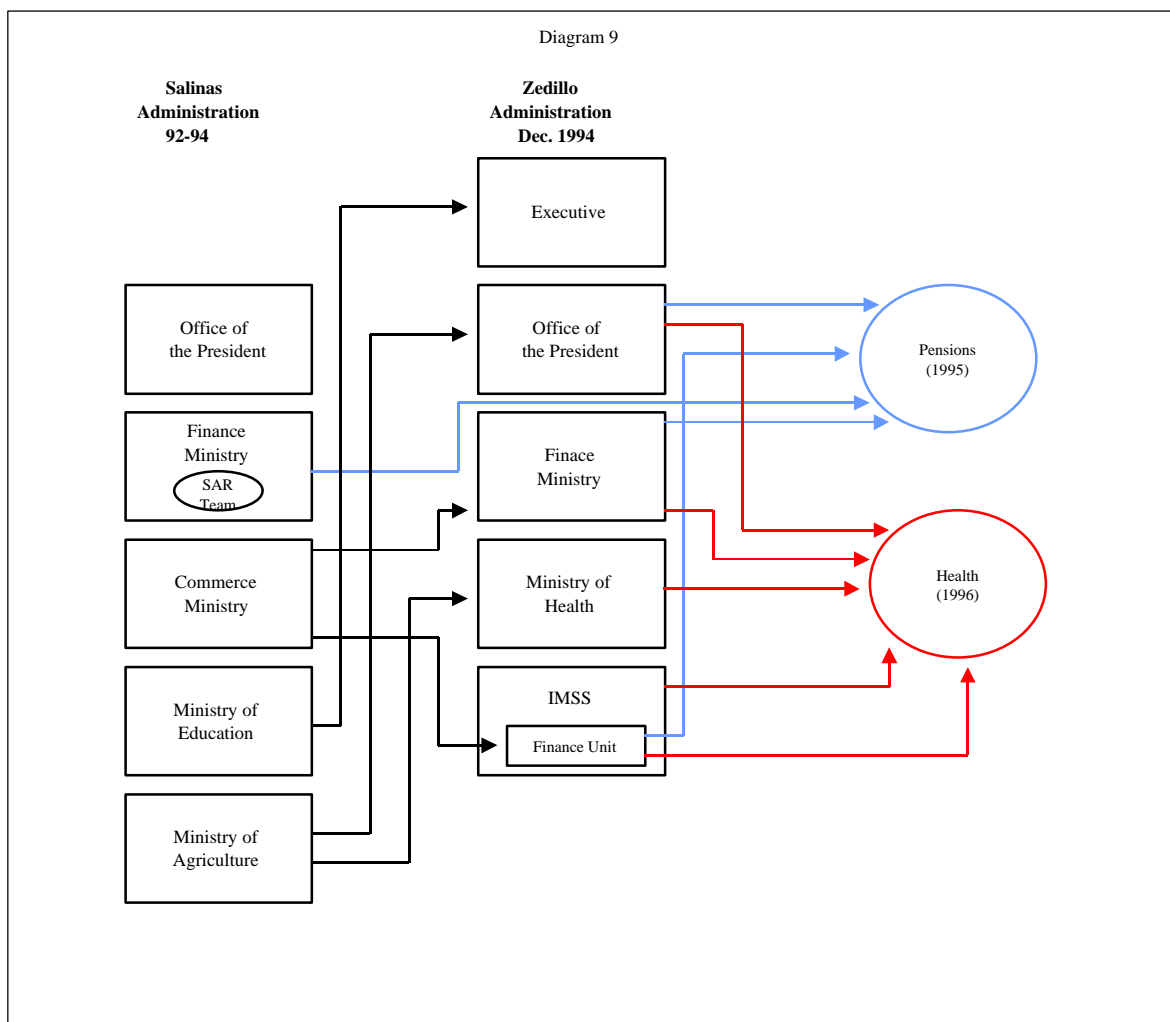

From mid-1993 through 1994, this change team worked to develop a proposal for the reform of the pension system. As was the case with Aspe's team, this new reform group did not formally consider including the health component in its project. This faction of the economic team followed the same strategy that had been used during the first generation reforms to pursue the pension reform. At the end of 1993, with the change of administration in sight, the Commerce Minister appointed Gabriel Martínez,¹¹⁵ one of his economic advisors and then head of the deregulation unit, to a position in the IMSS Finance and Systems Department. Here he was to form and lead a change team in charge of pursuing IMSS reform.

Thus a small change team of highly trained economists and actuaries, whose training and career experience were outside of IMSS, was formed and put in place within it, led by Gabriel Martínez, a junior member of the economic team. In this way, the team in charge of pursuing the pension reform as well as the financial restructuring of the IMSS was an extension of the economic change team in the core ministries. The vertical network of support for the change team in IMSS, came directly from the Finance minister—and former Commerce Minister—Serra

¹¹⁵ Gabriel Martínez had a PhD in economics from the University of Chicago. Since 1993, while still working at the Commerce Ministry, he was commissioned to interact and cooperate with the CEDESS group, a think tank for the IMSS directorate.

Puche.

With the economic crisis of December, 1994 and the resignation of Jaime Serra as Finance minister, Gabriel Martínez' change team was left without its single most important vertical supporter. This narrowed its scope of action considerably. Without the political backing of high level officials in the core ministries to give it political support, the change team was forced to slow down and reduce its reform agenda to remedial policies aimed at restructuring the defaulting IMSS finances. With very few exceptions in which the change team was able to maintain its policy agenda through isolation and a high quotient of technicalities, the change team was forced to negotiate policy changes with the IMSS union, a formidable veto group. Simultaneously, and also as a result of the economic crisis, the pension reform became a priority in the government's agenda. Thus the economic change team attracted the matter back to its realm and away from IMSS.

The Centro de Desarrollo Estratégico para la Seguridad Social (CEDESS)

Parallel to the social security reform formulation and the bureaucratic political maneuvering taking place within the economic change team, the IMSS director, Genaro Borrego, founded CEDESS immediately following his arrival. His aim was to participate more closely and, if possible, create the conditions under which the project might gravitate closer to the IMSS area of influence.

The task assigned to the CEDESS team was to develop an integral social security reform proposal along the same lines and terms that were being used by the economic team in the discussions about the subject. At the same time, and as the imprint of the IMSS directorate, it should go beyond the pension fund, and include a plan to reorganize the provision of health services. This was the first time that the reform of the health component of IMSS was included as an integral part of the reform proposal. Even so, from its outset the reform of the health component was not given the same level of priority as the pension system reform or the financial reorganization of the Institute's insurance funds.

The formation of CEDESS can be seen as an attempt by the IMSS to create a change team similar in nature and *modus operandi* to those used by the technocratic economic team, since it perceived this as an effective strategy to bring about policy change within a setting of resistance. The IMSS director also saw it as a good strategy to reach out to the economic team and establish closer ties of cooperation with this more powerful team.

The CEDESS team was thus comprised of apolitical technicians with similar backgrounds and policy experience as the technocrats in the Finance Ministry. Economists, mathematicians, and actuaries were hired to develop a technically sophisticated reform proposal in terms familiar to the technocrats of the economic and financial agencies of the government. Among the members of the CEDESS group, two stand out: Enrique Dávila, leader of the pensions team, and Mario Villafaña, leader of the health team. Enrique Dávila earned a Ph.D. in economics from the University of Chicago. His academic training was based on the principles of economic liberalism and free markets. His previous work experience was mostly in academia—teaching economics at ITAM and CIDE. Just prior to joining CEDESS, he worked as economic advisor to the head of the Deregulation Unit in the Commerce Ministry, where he became acquainted with the team of economists working on deregulation.

What made the CEDESS similar to a change team is that it was created apart from the IMSS bureaucracy, with policy makers drawn from outside the Institute, and isolated from possible pressure from interest groups within and outside the agency, including the IMSS union. However,

the IMSS was not successful in transforming the CEDESS team from a think tank into a change team because it lacked the power to give it the political support it needed to gain access to policy decision making. In other words, since the IMSS director was not part of the economic team in the core ministries, he was not powerful enough to endow the team with a vertical network that would empower them to confront resistance to change as well as the competing reform projects stemming from other places in government, notably from the economic team itself.

Also, CEDESS lacked a number of traits that are indispensable in a change team. The team lacked cohesiveness; it was comprised of individuals with very different academic training and with dissimilar work experiences in different institutional environments. It lacked a similar package of ideological premises about the role of the State and of the market, and thus lacked a common vision as to what the reform's objectives should be. There was no common ground among the team's members on which to solve their differences. The group did not have a clear leader who could guide the reform and who could act mediate between the different positions of the various members.

Finally, CEDESS members did not perceive themselves as a change team either. They thought of themselves as consultants whose responsibility was to develop technically sound reform proposals, but did not see themselves with the capacity to negotiate and implement them. Nor did they aspire to pursue the social security reform from a position of decision making power.

But the key missing element remained the lack of a vertical network. A vertical tie of support within the same agency that is to be reformed—in this case, the IMSS director—is not sufficient to empower a group as a change team. Some of the CEDESS group members had individual contacts with mid- and high-level officials in the Ministries of Finance and Commerce through their previous work experience that could be considered as part of a horizontal networks. But the economic team did not recognize the group as partners or as a change team with authority to decide and negotiate the reform project and strategies. Instead, the level of cooperation was more on the lines of CEDESS being considered a think tank whose research is used as input in the actual decision making.

As such, the team in CEDESS worked to develop concrete and efficient solutions to specific problems, but did not assume an encompassing mission defined in terms of a health sector reform or even an IMSS reform. Their scope of action was very limited. Thus their resulting analysis followed the ideological lines of the economic team more because CEDESS members perceived their role as subsidiary to the former, than because they had reached a common agreement on a policy position. Thus, in accordance to the economic team's liberal principles, the economists within CEDESS developed a reform proposal for the pension system that questioned the role of the State as the basic purveyor of social services. In terms of efficiency, their proposal stated the need to turn to market mechanisms and the private sector to manage the pension funds.

In contrast with the pension reform project, the proposal for the health component did not question the central role of the State as the main supplier of health services. The proposal put forth by Dr. Villafaña and the health team in CEDESS did not intend to restate the division between private and public responsibility for the provision of health services. It only put forward a series of internal measures to increase the quality of the service provision within the IMSS, through quasi market mechanisms such as doctor eligibility and competition.

The scope of the health component reform set out by the CEDESS team was very incremental. It did not propose the creation of new actors, such as private Health Management

Organizations (HMOs). Nor did it consider a substantial transformation of the old actor: the restructuring of IMSS in the area of health care by a systematic use of the opt-out and quota reimbursement policy. Instead, it advocated a series of incremental changes some of which are in pilot phase, as described in the previous chapter.

The Executive's social security inter-agency group

In view of the 1994 economic crisis the new President and the core ministries decided to push forward the pension reform proposal that had been developed during the previous years to substitute a fully funded individual account scheme for the pay-as-you-go pension system.

An inter-agency group was designated by the economic cabinet to adjust and negotiate the reform project within the Executive. The technical group designated by the economic cabinet was comprised of Enrique Dávila and Carlos Noriega from the Finance Ministry, Fernando Solís Soberon from the CONSAR,¹¹⁶ and Gabriel Martínez from IMSS. There were also representatives of the Ministries of Labor and Health, and from the Office of the Presidency.

The economic group assigned this technical team the task of developing the final pension reform proposals. Although the inter-agency team took into consideration the propositions developed at CEDESS, they did not grant it access to the decision making process.

The inter-agency group presented many of the characteristics of a change team. It was formed by liberal economists with high technical qualifications, who shared a common vision on the path and objectives of the reform. The fact that there was a clear presidential line regarding the content of the pension reform proposal contributed to unify the group ideologically and programmatically. Many of the members of this team were a part of the wider group of technocrats who had implemented the economic reforms in previous years. This influenced their perception of how a reform process should be carried out both in its content and in its process. As with the economic reforms, this team considered that the most efficient way to transform the social sector was to modify the rules and incentives that guide the relevant actors' actions as a means to trigger change. According to their perception, this would bring about policy change without having to directly confront the interest groups affected by the reform in the short run.

The economic team's representatives, assembled in the economic cabinet, empowered the group to adjust and negotiate the reform proposals. So, the inter-agency group had a vertical network of support that gave it political strength. It also had horizontal networks that widened its maneuvering capacity to avoid any possible external influence or pressure from interest groups at this stage of the reform process. This inter-agency group worked in isolation and did not open the discussions on the reform's content in other arenas outside the Executive.

Formally, an inter-agency group's function is to represent the various government agencies relevant to a specific arena of policy-making and to create an arena for representation and negotiation. However, because this group's members saw themselves as colleagues with a same purpose beyond their respective agencies' policy agendas, they put aside their institutional position and worked as a task force. In that manner, this group operated in resemblance to a change team, since it worked as a cohesive group, where institutional points of view were not relevant.

The inter-agency team briefly considered restructuring the IMSS health component as it was formulating the final proposal of the pension reform. However, it was precisely this team that

¹¹⁶ The National Committee for the Retirement Savings System.

decided to postpone it in order to ensure the approval of the new pension scheme in Congress.

In making policy choices, the group resorted to several political strategies to obtain consensus among the relevant ministries within the Executive. For instance, its decision to instrument a transition regime for the financing scheme of the IMSS health component can be interpreted as an obfuscation strategy (Pierson, 1994). In this manner, those agencies that opposed a single flat quota—notably the Labor Ministry—were unable to distinguish clearly the technical subtleties of the proposal which was presented in a transitory article to be amended in the Law.

The inter-agency group also chose not to include the reform of ISSSTE,¹¹⁷ the state-government pension schemes, and the public housing agency in the same reform agenda as IMSS, although they all faced similar problems with equal or worse urgency. This choice was aimed at dividing or reducing the size of a probable coalition against the reform, thus limiting the potential for opposition (Pierson, 1994).

The inter-agency group isolated itself from the possible influence of pressure groups. It sought to build consensus among the relevant government agencies within the Executive, but it did not follow the same strategy with the bureaucratic or societal groups that would be affected by the reform. Since the reform proposal it was preparing was aimed at changing rules and incentives, and did not address a major reform in the provision of IMSS health services, consensus building with its bureaucracy, especially with the IMSS union, was not seen as necessary for the reform's implementation.

Only the requirements of the institutional context or the need to rely on provider groups for the reform's implementation, forced the economic team, and its inter-agency group, to open up for negotiations with groups outside the Executive. Such was the case of the approval of the New Social Security Law in Congress, and thereafter, its implementation within IMSS. By the same token, it must be pointed out that interest groups whose interests might be affected by the reform—i.e., provider groups like the IMSS union (SNTSS)—also chose the place and moment (the veto point) in which its resistance strategies would have a major impact. The veto points in which the reform group was forced to open the process to the influence of interest groups coincide with those points at which the SNTSS is strongest, and thus where it chooses to get politically mobilized. These points include the Congress during the legislation stage, and, the IMSS at the implementation stage, where policy change is entirely dependent on it (Diagram 10).

¹¹⁷ The State servant's social security agency

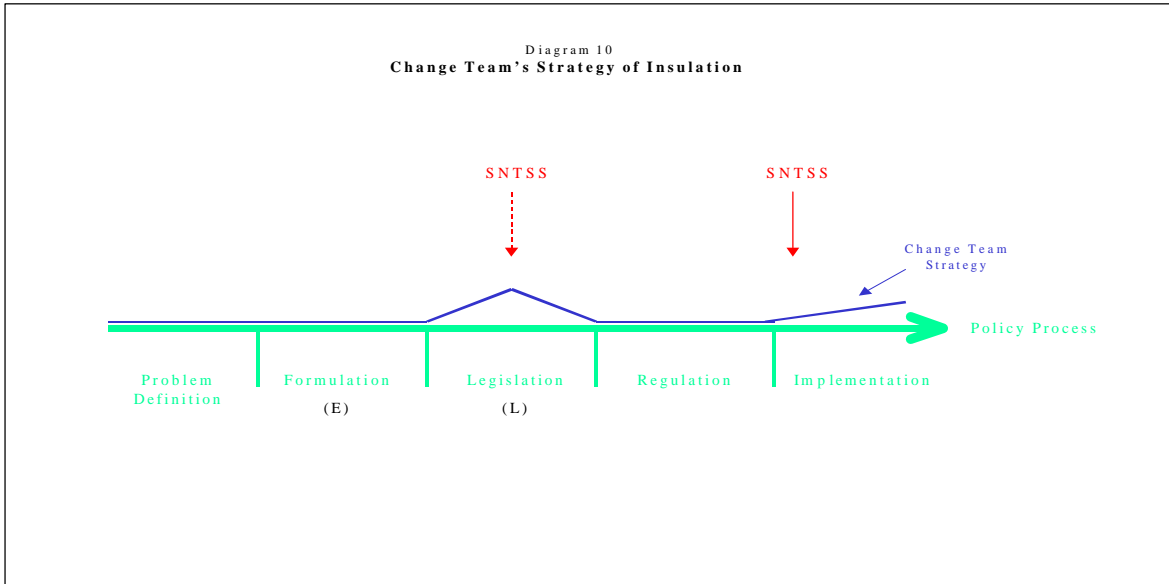

Finally, the pension change team decided to resort to an incremental strategy to increase the feasibility of implementing the reform proposal. It did not seek an integral reorganization of social security. Instead, and in accordance with the President's priorities, the team decided to push forward the restructuring of the pension system and the financial reorganization of the IMSS, and postpone the health component reform.

Once the President and the relevant ministries had agreed on the content of the Law initiative, the technocratic group's strategy was to assign the responsibility of brokering the reform with the veto groups in Congress and within the IMSS bureaucracy to the IMSS directors. This gave the Institute's director the opportunity to influence the decision making process around the reform, since its role as political broker lobbying the proposal in Congress, gave him the authority to discuss the technical content on political feasibility grounds.

Generating support for the reform among businessmen and organized union leaders was considered relevant because it could influence the legislators' position towards the initiative. In order to inform congressmen in the Lower and Upper house about the benefits of the proposal, the IMSS directorate met personally with each one of them. It was especially important to generate support for the reform among PRI legislators, because they constituted the majority necessary to approve the reform proposal.

As a strategy of compensation (Pierson, 1994) to PRI legislators, IMSS introduced in the reform initiative several "bargaining chips." In other words, these were items in the reform proposal that were not a priority for the Executive and could thus be "conceded" during negotiations and bargaining in Congress in exchange for the legislators' vote. There is a possibility that the proposal to make the Law amendments necessary to apply the opt-out and quota reimbursement policy more systematically was included for this purpose. And indeed, the removal of this amendment was the central condition in order for PRI representatives to vote in favor of the New Social Security Law.

It can be concluded that the IMSS' political maneuvering is what made the economic team's technocratic reform politically feasible. After the approval of the New Social Security Law in December 1995, the IMSS health component reform process was going to continue in two parallel arenas. Within IMSS, Gabriel Martínez' change team continued its work on the financial reengineering of IMSS, while the Executive was soon to form another inter-agency group to study

policy options concerning the new actors in the health system—the HMOs—and with it, the implementation of the opt-out and quota reimbursement option.

THE CHANGE TEAM WITHIN IMSS

In late 1993, a small change team of highly trained policy makers, outsiders by training and career experience to the agency being reformed, was assigned to the IMSS Finance and Systems Division to implement the Institute's financial reorganization. The team's leader, Gabriel Martínez, participated in all stages of the reform process—if only tangentially at the beginning—beginning when the Ministry of Commerce faction took control of the Social Security reform project within the economic team. In his position as head of the Deregulation Unit in the Ministry of Commerce, he helped develop the proposal to reform the structure of the pension system and to reorganise the financing scheme of the insurance funds. Thereafter, he was assigned to IMSS during the Salinas administration to prepare for the restructuring of IMSS finances. In that position, he was also part of the inter-agency group that adjusted and negotiated the pension reform proposal within the economic team before it was presented as a Law initiative to Congress. After the approval of the law in Congress, he and his team continued implementing their reform agenda within IMSS.

To undertake the financial restructuring of the IMSS, Gabriel Martínez, now head of the Finance and Systems Division, formed a small and cohesive group of economists, actuaries, and accountants. This group presented many of the characteristics of a change team. Its members had high technical qualifications and shared common ideological and programmatic principles. It also had a clearly defined leader who had the last decision when assessing options.

The team's reform proposal followed the same assumptions on which the economic reforms were based. Through financial adjustments, the group intended to modify the rules and incentives that regulate IMSS' internal proceedings in the administration of funds and the provision of services. This change of incentives was expected to lead to more transparent, equitable, and efficient processes without the need to directly confront the interest groups involved within IMSS.

The team works in isolation, with the sole exception of Eduardo González Pier, the Division's planning coordinator. With a Ph.D. in economics from the University of Chicago, he was also a liberal technocrat, but he was the one in charge of shielding the team from interest group pressure and of brokering the team's agenda within IMSS, particularly with its bureaucracy, and with business groups interested in IMSS reform.

Following the resignation of the Finance minister as a consequence of the economic crisis of December 1994, the change team lost the key member of its vertical network of support. Although this narrowed considerably the team's scope of action, after the approval of the New Social Security Law, it continued to work on the restructuring of IMSS finances, and some elements of IMSS health care provision reform, such as deconcentration of service provision, performance incentives, and coverage extension.

However, the lack of clear support from a core ministry forced it to negotiate and look for consensus with the IMSS directorate and, most importantly, with the SNTSS. This limited the group's room for maneuvering and forced it to accede to the bureaucracy's conditions and resistance. It thus can be argued that the team has been successful in bringing about policy change in the financial areas, where it has greater control of changes, but has been slowed almost to a halt in those areas where it depends on the IMSS bureaucracy, especially health

services providers, to bring about change in the provision of health care.

Its good performance in restructuring the financing aspect of health service provision has enabled the team to maintain key horizontal networks of support within other governmental agencies, particularly with officials promoting sound fiscal policies in the Finance Ministry. Of special importance has been the Finance Under-Secretary, Santiago Levy, who was in charge of the Zedillo government's social sector budget, which was established before Martinez' assignment to IMSS. This has granted the group some room to maneuver, as well as a degree of job security, but it has not been enough to support faster and deeper changes in the health care provision component of the reform agenda.

THE EXECUTIVE'S INTER-AGENCY HEALTH CARE GROUP

After the approval of the New Social Security Law in Congress, an inter-agency group within the Executive continued to work on a project to regulate the health sector. Their intention was not to promote an integral reform, but instead to implement a reduced number of concrete proposals. Their initial objective was to simultaneously regulate the emerging HMO market along with the IMSS opt-out policy and the indirect provision of health services in IMSS.

While officials in the Finance Ministry and the Office of the President considered it a priority to regulate the emerging HMO market in order to guarantee the new industry economic certainty and protect the users, the regulation of IMSS' opt-out policy and indirect provision of health services, although relevant, was not considered a priority.

The inter-agency group was comorised of officials from the health sector's agencies—the Health Ministry and the IMSS—along with the core government agencies—the Finance Ministry and the Office of the President. The team was backed and supervised by the President's Chief of Staff. The group's configuration and its location within the Executive meant that the project was given strong backing from the higher government echelons. This gave its members enough space of maneuver to draw proposals unaffected by the health sector's interest group pressure.

This inter-agency group, as the one that had earlier promoted the pensions system reform, presented most of the characteristics of a change team. It was formed by a reduced number of policy makers with high technical training—most of them were economists and lawyers—who were assigned the formulation of a specific aspect of the health reform. The team had a clearly recognized leader with sufficient technical knowledge and political leverage to guide the group. It was also an ideologically and programmatically cohesive group that isolated itself from external interest group pressure. Finally, it had a broad set of vertical and horizontal networks of support, which included the President.

Although this group had the formal purpose of representing the agencies involved in the reform process, most of its members subordinated this function to that of involving themselves as technical, apolitical policy makers in the formulation of the reform proposal. Among the team's members, only the IMSS officials used the inter-agency group as a forum of agency representation to try to influence the decision making process.¹¹⁸ However, the team's leader had enough political leverage to maintain the group's cohesiveness around the predominant reform

¹¹⁸ Given the political costs of confronting IMSS union without the full backing of the President, the IMSS directorate did not have the incentives to see the opt-out policy regulation take form, as it would be its responsibility to implement it. With the sole exception of Gabriel Martinez, IMSS officials invited to the inter-agency group used it as a forum to make their case that implementing the opt-out option was politically unfeasible.

objective.

The team approached the reform as a regulation problem. This meant setting up the rules for and creating new health providers, such as the HMOs. It thus avoided the reform proper of the existing provider institutions, notably IMSS itself. Instead, it focused on creating a health insurance scheme for middle income groups that would eventually force the transformation of IMSS via market competition. With this strategy, a direct confrontation with the IMSS bureaucracy was avoided, but the health sector's integral reform was postponed.

The regulation of the emerging HMO market was also intended to boost private investment in health infrastructure. With the simultaneous regulation of the IMSS opt-out policy, the team expected to promote a shift of IMSS affiliates to the new HMOs. The introduction of competition by creating new health service providers and allowing IMSS affiliates to switch to them, was expected to trigger improvements in health care quality. As they gained economic strength and political weight, HMOs would also represent a new base of support to confront the old agency's bureaucracy, particularly its union.

However, when the team was made aware of the IMSS union's mounting political pressure against the implementation of the opt-out option¹¹⁹ it concluded that the intention to regulate both issues at the same time could affect the political feasibility of introducing the HMO market regulation. Thus, given that the opt-out policy was not a priority and the benefits of its impact remained unclear, the regulation of IMSS opt-out policy was stopped and postponed once again.

The following diagram shows a simulation of tendencies of old and new actors in the health sector¹²⁰ following the series of assumptions and decisions described above. The graph shows in solid lines the historical growth tendency of the old actors and the increase in number of new actors as a result of a more predictable market due to the new regulation. With the postponement of the IMSS opt-out policy, instead of a substitution effect—in which old actors would eventually diminish in number and target population in favor of new actors, what can be appreciated is the simultaneous presence of both old and new actors, increasing the total number of providers in the health sector. In this scenario, no substantive change is obtained beyond the emergence of the new actors. The sector remains unreformed.

The dotted lines show the decision makers' assumption that, if IMSS' opt-out policy regulation is eventually sanctioned, the substitution effect would then take place with the eventual downsizing of the old actors (IMSS) and a more significant presence of new actors. In this scenario, a substantial reform of the sector would be obtained via an incremental and indirect strategy, based more on market tendencies and regulation than on direct short-term institutional change (Diagram 11).

¹¹⁹ This included union leaders' declarations in the press that the government was secretly planning to "privatize" IMSS, which was echoed by opposition party members.

¹²⁰ The graph does not represent quantifiable projections.

Diagram 11
Change Team Strategies
Old Actors / New Actors

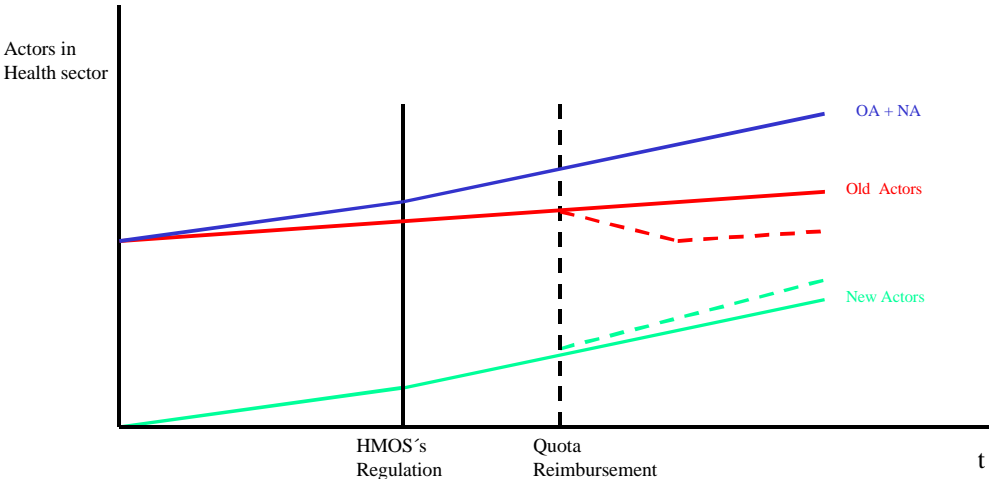

*Indicative of tendencies. It does not accurately represent values or proportions.

CONCLUSIONS

The technocratic characteristics of the last two administrations, along with the presidential control over the Legislature and Judiciary, made it possible for the Executive to transform an inter-agency group into a change team and empower it to promote a reform agenda beyond the control of the provider bureaucracies that would be affected by it. In a scenario where the main veto point is located within the Executive, inter-agency groups may negotiate and implement a reform proposal without having to open the process to other actors interested in influencing it.

The participation of interest groups and governmental agencies is restricted and entirely controlled by the Office of the President and the core ministries, who determine both the degree of participation and the composition of the change team that is assigned the reform formulation. Also, due to the Executive's concentration of power and the secondary role played by other institutional arenas, notwithstanding Congress, technocratic change teams find an ample space for maneuver only limited by their vertical networks' interest in their reform agenda.

In a more democratic context, with a multiplicity of political actors and veto points, the inter-agency group would hardly be able to isolate itself completely from external pressures. Also, negotiations around policy reform formulation would take place in the legislative branch, in a more open and participatory process.

The use of change teams as a strategy to bring about economic reform seems to have been effective in promoting change in those aspects of health reform that respond to new regulation and financial reallocation. However, this initial success hides what seems to be a serious limitation of this strategy in promoting comprehensive reform in the provision of health services.

While the use of change teams has proven its efficacy in inducing policy change through regulation and financial reengineering, it has failed to bring about the restructuring of public provider institutions. This has limited the scope of health sector reform. In order to achieve the transformation of the sector's old provider organizations, their bureaucracies—and particularly their organized provider groups—who are normally excluded from the reform process need to be taken into consideration; either via consensus building or confrontation. So far, given their nature and position, change teams have been unable or unwilling to do either. In that case, further exploration needs to be made about the usefulness of change teams in enhancing the State's capacity to bring about comprehensive reform in the social sector.

ANNEX I: POLICY TRACER

I. INTRODUCTION

The objective of this study is to analyze the reform of the health component of the main institution of social security in Mexico: the Mexican Institute for Social Security (IMSS). The IMSS is the largest employer in the country. In 1998 the Institute had 351,475 workers, 5.4% more than in 1991. During 1998, the IMSS provided 438,693 medical examinations daily, took 349,138 laboratory tests, performed 5,119 surgical operations, and 4,700 women gave birth there, one out of three Mexicans is born within the Institution (see Table 4).

Table 4

TYPICAL DAY IN THE IMSS								
(accumulative January-December) a/								
	1992	1993	1994	1995	1996	1997	1998	1999
Given Medical Examinations	320,117	340,541	357,269	382,731	397,390	409,800	413,949	438,693
Laboratory Studies	300,819	309,532	328,757	336,201	340,886	341,743	354,426	349,158
Radiodiagnosis Studies	33,259	35,217	36,445	36,969	37,976	38,692	39,644	40,276
Surgical Interventions	4,737	4,712	4,881	5,112	5,286	5,356	5,446	5,119
Attended Deliveries	1,046	2,033	2,048	2,177	1,812	1,801	1,780	1,680
Hospital Discharges	5,038	5,128	5,289	5,225	5,135	5,181	5,027	4,700

a/ Revised data considering the last date of the information in the medical area.
Source: Instituto Mexicano del Seguro Social

We can observe the size of the Institution and its importance for the population, by the amount of people that are insured and that are users of the services of the IMSS. The insured population grew from 1992 to 1998 in 5.33%, going from 37,464,960 people in 1992 to 39,461,60 in 1998, while the total population grew in 9.4% (see Table 5) as we will mention, the financial crisis of 1994, caused a decrease in employment.

Table 5

USERS AND TOTAL INSURED POPULATION								
(data to December in thousands)								
	1992	1993	1994	1995	1996	1997	1998	1999
Permanently Insured	10,104	10,048	10,293	10,112	10,916	11,798	12,245	12,297
Families of the permanently insured	20,800	19,947	19,384	18,638	20,113	21,540	22,065	22,027
Eventually Insured	1,264	1,269	1,268	820	979	916	1,366	1,381
Families of the eventually insured	2,955	2,937	2,915	1,895	2,253	2,073	3,030	3,060
Pensioned	1,259	1,352	1,433	1,522	1,603	1,680	1,735	1,740
Families of the pensioned	1,083	1,184	1,261	1,337	1,397	1,455	1,501	1,505
Total of the insured	37,465	36,737	36,554	34,324	37,261	39,462	41,942	42,010
Total of the insured users	23,360	24,177	24,315	24,232	24,595	24,882	27,238	26,472

Source: Instituto Mexicano del Seguro Social

The study focuses in the introduction on the structural adjustment change made in Mexico and several indicators about the Mexican health system within the sector reform. There is also a subsection in which the financial reform is explained focusing mainly on the Illness and Maternity Insurance (SEM) as this is what we define as the health component of social security and the Family Health Insurance (SSF). The method used to systematize the analysis was that of nine policy tracers in order to determine how and if the reform has met its goals compared with what the Mexican government committed to during President Zedillo's administration.

Finally, the last section presents the conclusions where the most relevant aspects of the reform are reassessed in the context of the policy tracers, with a thorough evaluation of the reform of the health component within the IMSS.

II. BACKGROUND

A. Economic Background

The administration of President Ernesto Zedillo (1994-2000) included in its agenda a Health Sector Reform Program that had already been analyzed since President Carlos Salinas' (1988-1994) term. However, the financial crisis, that burst out less than a month after Zedillo took office, in December 1994, made the government bring to a halt the majority of its plans of reform in order to concentrate in the control of the macroeconomic variables. This was the case of the PRSS among other reform programs (Table 6). The PRSS does not appear until many months after the crisis had begun; it is one of the first programs to be published. However, its main lines were too general. The pension reform had become a priority as the government's answer to the crisis in order to promote domestic savings, one of the main causes of the financial problem. The reform of the health component in the IMSS only enters into the discussion as a secondary aspect of that initiative.

Table 6

MEXICO'S ECONOMIC INDICATORS (1992-1998)							
	Inflation (%)	GDP Growth ^{a/}	Exchange Rate ^{b/}	Growth of the Exchange Rate (Devaluation) (%)	Open Unemployment Rate ^{c/}	Complementary Unemployment Rate ^{c/}	Economically Active Population ^{d/}
1992		3.5	3.091	2.4	2.7	5.1	54.0
1993	8.01	1.4	3.115	0.8	3.3	6.2	55.1
1994	7.05	4.5	3.374	8.3	3.6	5.7	54.8
1995	51.97	-6.2	6.405	89.8	6.1	8	55.6
1996	27.70	5.1	7.598	18.6	4.7	6.3	55.7
1997	15.72	6.8	7.915	4.2	3.1	5	56.4
1998	18.61	4.8	9.139	15.5	2.8	4.1	56.2

a/ Percentage change at 1993 prices.
b/ Daily average pricing of Mexican pesos per US dollar.
c/ Information to each year fourth semester.
d/ Population of 12 years of age or more.

Source: Banco de México, Instituto Nacional de Estadística, Geografía e Informática.

B. Structure of The Mexican Health System

The Mexican health system is composed by an heterogeneous group of public and private institutions. The public institutions can be divided into the social insurance and public assistance institutions for the uninsured population.

Within the social insurance system we can find the IMSS, ISSSTE, the health services for Oil Workers (SSPEMEX), the health services for the army (SSSD), and the health services for the navy (SSSM).

The health services for the uninsured population and public assistance are composed of the Ministry of Health (SSA), the services given by each one of the states, those provided by the social security for the rural poor (IMSS-Solidaridad) and the health and welfare services provided by the System for the Integral Development of the Family (DIF), as well as the services given by the Federal District (DDF). Besides the program for the expansion of coverage towards the poor and the very poor, there is a poverty alleviation covering education, health and nutrition (PROGRESA).

On the other hand, Mexico has private health institutions that cover approximately 34% of the total demand of the population.¹²¹ It is worth noting that this group covers the richest population as well as the poorest population, all of those whose demands for health services are not covered by public services.

The Private Health Insurance only covers 2.35% of the total population.¹²² In 1998 all the insurance companies in Mexico covered 2'250,924 people (Table 7).

Table 7

PRIVATELY INSURED POPULATION	
	Health Insurance
1994	1,583,230
1995	1,656,557
1996	1,687,778
1997	2,188,102
1998*	2,250,924
*Preliminary Data	
Source: Asociación Mexicana de Instituciones de Seguros	

However, there are substantial overlaps between the different institutions that provide health services. According to Table 8, in 1997, over 8.3% of the total of the country's population could be covered only by public institutions, this without considering private providers.¹²³ For instance, the same family can be insured by two or more social insurance institutions and use the services provided for the uninsured population at the same time have a private medical insurance and still make out-of-pocket payments to private independent providers. Duplicity, scarcity and bad use of the resources are all found in the health sectors as a whole.

¹²¹ This estimator has been obtained from the Encuesta Nacional de Salud of the INSP in 1994.

¹²² Mexican Association of Insurance Institutions (AMIS).

¹²³ Total population is estimated at 93.7 million (CONAPO, 1997).

Table 8

Notwithstanding, in 1994 10 million people did not have any access to health services, that is why the Ministry of Health designed and implemented an essential package that is working since 1996. Until 1998, 6.6 million people were covered by this package (Table 9).¹²⁴

Table 9

COVERAGE OF THE ESSENTIAL PACKAGE			
(population in thousands)			
Entity	1996	1997	1998
Campeche	51.1	43.0	45.2
Chiapas	853.4	1,149.0	1,265.0
Chihuahua	-	150.0	176.2
Durango	-	52.0	60.2
Guanajuato	-	39.0	48.3
Guerrero	785.1	859.0	797.3
Hidalgo	262.3	398.0	422.9
México	-	331.0	386.6
Michoacán	125.5	70.0	79.0
Nayarit	-	27.0	30.6
Oaxaca	964.2	1,014.0	1,083.2
Puebla	253.4	619.0	693.4
Querétaro	-	44.0	55.0
San Luis Potosí	181.2	185.0	191.5
Sinaloa	-	33.0	37.6
Veracruz	134.1	829.0	1,014.6
Yucatan	159.1	80.0	101.8
Zacatecas	108.7	78.0	81.5
Total	3,878.1	6,000.0	6,569.9

Source: Secretaría de Salud

C. Financial Structure of The Mexican Health System

The financial structure of the health system in Mexico is unclear up to 1994, as because of the absence of a national accounts system. For instance, the World Bank found in 1990 that the share of resources spent in health was equal to 3.2% of the Gross Domestic Product; for the Pan-American Health Organization (PAHO) it was 3.8%. Meanwhile, in 1995 FUNSALUD developed a project where a National Health Accounts System (SCNS) for Mexico was designed and corrected the sub registration of the resources spent in this sector. It demonstrated that in 1992, the money spent in Mexico in health was between 4.8% and 5.7% as a percentage of the GDP, and that the private sector had been historically undervalued.¹²⁵

The National Health Account System for Mexico showed that there existed an inappropriate share by financing agency because 30% of the sources of financing for health came from private firms, 21% from the Government and 49% from the households. Furthermore, 45% of these resources were oriented to the social security fund, 13% to the public assistance fund (uninsured),

¹²⁴ Data according to the Ministry of Health and Welfare (SSA).

¹²⁵ Álvarez, F. Cruz, C. Frenk, J. (1994) *Las Cuentas Nacionales de Salud y el Financiamiento de los Servicios*. Mexico: FUNSALUD. Documentos para el Análisis y la Convergencia. Pp. 51.

2% to the private health insurance fund and 40% to the private virtual fund, used to finance out-of-pocket payments which were insufficient to afford complex and highly technical health care demands.¹²⁶

The SCNS show inequities between institutions: the yearly per capita expenditure for the uninsured population who received medical attention in the SSA, varied from a minimum of \$85.9 to a maximum of \$179 between 1992 and 1995.¹²⁷ During the same period, the per capita expenditure for the population who received treatment at the IMSS varied from \$561.2 to \$608.5 pesos. The same expenditure for the private sector varied from \$1,504.4 to \$1,844.8 (Table 10, Diagram 12).

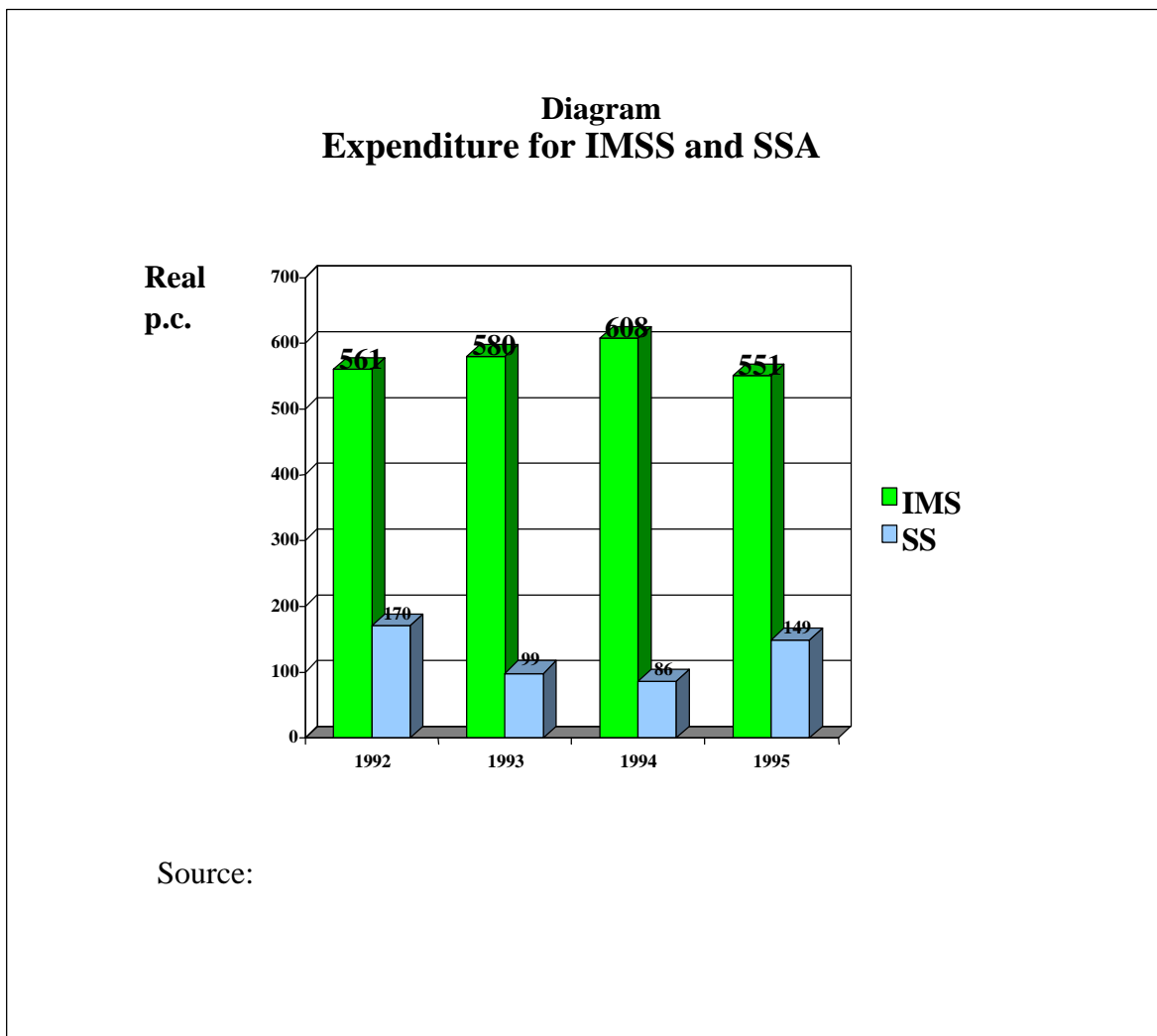

¹²⁶ As a result that study proposed: a) duplicate the government participation, from 21% to 40% and canalize the resources to the public assistance funds increasing it from 12% to 30%; b) decrease the private virtual fund from 49% (out-of-pocket payments) to 5% or 10% and give the rest 44% to the public or private prepaid systems; c) design new public and private prepaid schemes; d) create a culture of insurance and make it more efficient and aggressive; e) develop a public and private mixture of the partial and integral contracting out of services under the cost-effectiveness criteria.

¹²⁷ According to the Banco de México the average exchange rate in 1992 was of 3.0905, and in 1995 6.4049 Mexican pesos for one US dollar.

Table 10

The most recent published information about the relative share by financing source, by fund and by provider is shown in Diagram 15. As it can be observed, this data reflects source allocation up to 1995; therefore, the impact of the New Social Security Law (July 1997) and the subsequent reallocation of resources is not reflected.

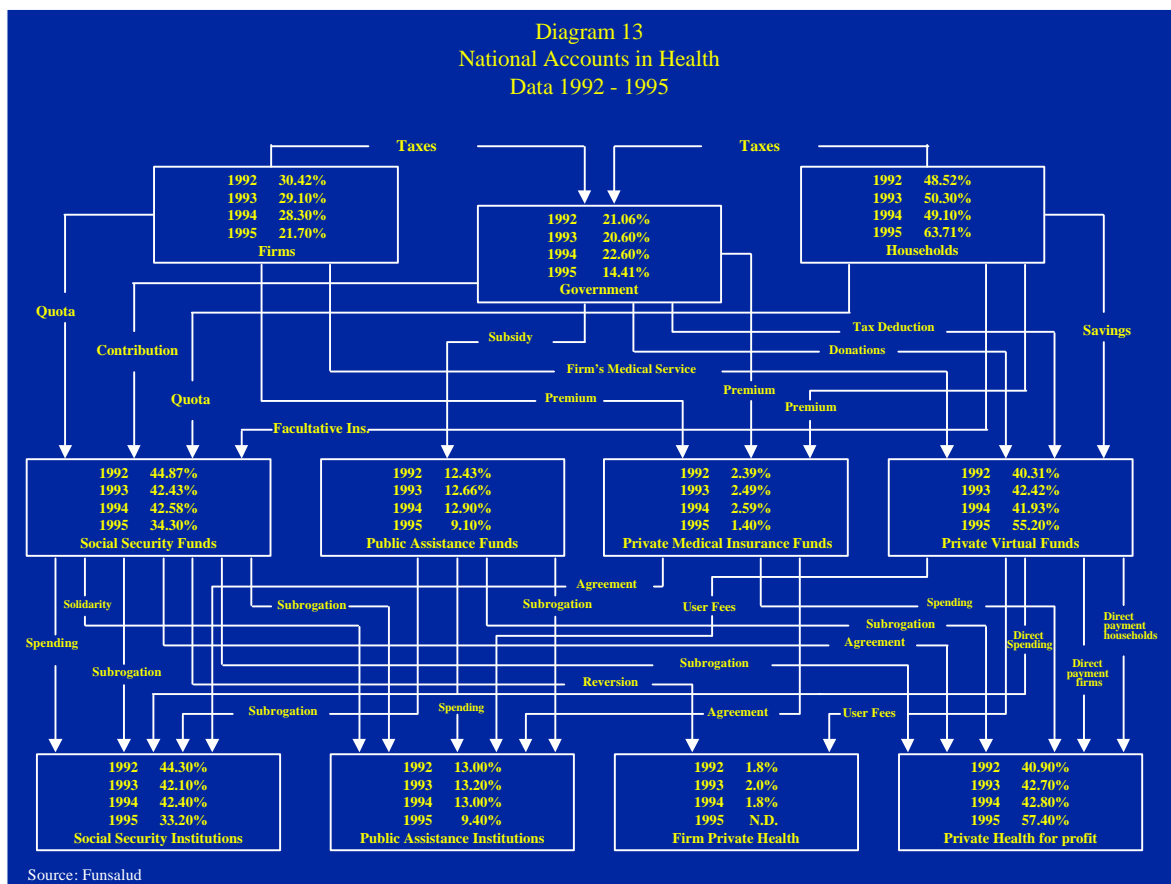

There was a low Government outlay: between 1992 and 1995 it participated with 20.6% and 22.6% of the total of the resources for health. As a result of the economic crisis and the structural adjustment policies, the problem worsened since the Government's share decreased from 22.6% in 1994 to 14.4% in 1995. This decline had effects on the uninsured population, from 12.4% to 9.1%, basically this fund depended on the public subsidy in order to finance the health services.

Furthermore, during the adjustment period (1995), there was an increase in the participation of the households as the main source of financing for health, from 49.1% in 1994 to 63.7% in 1995. This situation made larger the private virtual fund used to pay the out-of-pocket payments, since it increased from 42% in 1994 to 55.2% in 1995.

Finally, until 1995 there were closed schemes where the same institution financed and provided the service, so there is no evidence of an increase of the public private mix in the financing and delivery of health services.

In 1997, changes in public finances that resulted from the financial reforms of the social security implied increasing government outlays that before the application of the New Law (July

1997) it allocated 0.06% of the GDP in the Illness and Maternity Branch, and after the implementation of the New Law in that same year, the outlay was equivalent 0.45% of the GDP. In 1998, the federal government participated with and equivalent to 0.46% of the GDP (Table 11). However, this increase was not the same for the uninsured population, there were some increases for the SSA, but not as significant as the one given to the insured population of IMSS.¹²⁸

Table 11

EMPLOYER-EMPLOYEE PARTICIPATION AND FEDERAL GOVERNMENT PARTICIPATION BY INSURANCE BRANCH								
(data in millions of pesos)								
	1992	1993	1994	1995	1996	1997 1st Sem	1997 2nd Sem	1998
Work Hazards								
E-E Quota	2,477.60	3,054.20	3,907.00	3,979.20	4,798.60	2,841.60	3,468.50	7,505.90
Illness and Maternity a/								
E-E Quota	14,092.30	16,975.30	20,915.90	22,799.10	28,310.20	17,452.40	16,884.00	38,340.00
% GDP	1.25%	1.35%	1.47%	1.24%	1.13%	1.10%	1.06%	1.01%
FG Quota	963.4	1,118.80	1,333.10	1,474.40	1,658.10	997.9	7,121.40	17,428.10
IVCM (Pensions) b/								
E-E Quota	8,648.70	10,207.40	12,472.20	13,821.90	17,440.40			
% GDP	0.77%	0.81%	0.88%	0.75%	0.70%			
FG Quota	501.2	571.6	684.4	761.3	970.8			
Disability and Life								
E-E Quota						10,729.60	4,763.50	9,637.40
% GDP						0.68%	0.30%	0.25%
FG Quota						589	287.2	468.7
Day Nurseries c/								
E-E Quota	1,179.10	1,403.50	1,695.80	1,839.50	2,269.60	1,405.30	1,636.70	3,735.60
% GDP	0.10%	0.11%	0.12%	0.10%	0.09%	0.09%	0.10%	0.10%

Descriptions: E-E quota is employer-employee quota; FG quota is Federal Government quota
The shadowed area is within the IMSS' New Law
a/ Includes Medical Expenditure for the pensioned (1.5%) and Family Health Insurance
b/ From the New Law (2nd semester 1997) it is divided in two insurances: Disability and Life (4%) and Retirement, Suspension in Old Age Insurance (4.5%)
c/ From the new Law it is Day Nursery and Social Benefits
The GDP at current prices of 1997 was divided in two in order to estimate the GDP for the first and Second Semester.
From the New Law there is no available data on the Retirement, Cesantia in Advanced Age and Old because the money goes directly to the AFORES and it is not administered by the IMSS
Sources: IMSS and INEGI

III. ANALYSIS OF THE HEALTH COMPONENT OF THE IMSS BY POLICY TRACERS

In this section we present nine policy tracers, each one presented with the information about its main problems and forms to solve them, its inclusion in the Health Sector Reform Program (1995), the advances made in the period of implementation of the reform between 1995 and 1998, the commitments done for the year 2000, the legal, labor, economic and administrative requirements, and finally an evaluation of the speed, scope of the reform process.

The policy tracers to be analyzed are:

- A. Financial Restructuring
- B. Desconcentration and Regionalization of the IMSS
- C. Institutional Model for Comprehensive Health Services (MIAIS)

¹²⁸ According to the Cuarto Informe de Gobierno 1998 the public sector expenditure in health was in 1996 and in 1997 equal to 2.1% of the GDP.

- D. Medical Areas of Desconcentrated Management (AMGD)
- E. Family Health Insurance (SSF)
- F. Family Doctor Eligibility and Performance Incentives for Family Health Centers
- G. Performance Incentives
- H. Costing according to Diagnosis-Related Groups (DRGs)
- I. Contracting Out of Health Services.

A. FINANCIAL RESTRUCTURING

The main problems that could be detected related to the financial restructuring of the IMSS were, among others, the need to create reserves and mechanisms that could allow mid term planning. It was essential to strengthen the financial mechanisms in order to guarantee the reserves of each fund. The long term reserves were being used before to support short term cash necessities that made the debts in some years larger than the reserves. In the New Law the pension fund independent of the IMSS and managed by private firms called AFORES, so the main origin of resources that covered the deficits in the current expenditure by cross-subsidies was eliminated and the resources are administered by private firms. In The New Law the short-term liabilities that the federal government had to assume because of the pensions generated in the Old Law were reduced. Now the Institute has to reveal its passives and has to evaluate in more detail the evolution of its expenses.

Also, the IMSS needed to overcome inequities and the discretionary allocation of resources caused by the inertia in the resource allocation. Previously, resources were allocated according to historical budgets. Now resource allocation is based on a resource allocation formula that included the capital cost to prevent from this capitalization deterioration. It was very important to include the costs of capital in order to generate funds that would pay medical equipment. To solve this problem, an administrative financial instrument was established with a legal base that would prevent the misuse of the reserves, so actuarial calculations by branch were established in order to know the evolution of the long-term costs.

In 1995, the financial reform was implemented however, there were no changes in the financial decision-makers within the Institution. Between 1995 and 1996 the cost of capital was incorporated in the financial operations. A new budgeting model was structured with explicit formulas and policies that emphasized equity in budget allocation. Moreover, new formulas were established that included variables such as age and mortality, adjusted by sex, in order to incorporate the demographic transition and epidemiological problems, as well as the effects on the demand for health attention.

As a result, on Table 12 we can observe the financial restructuring of the SEM, in 1997, the surplus was equivalent to \$1,761.4 million pesos. In order to bring this into context under the Old Law, in 1996 the deficit was of \$1,146.5 million pesos, 3.54% of the total expenditure in that branch, and in 1998 there was a surplus equal to \$1,294.2 million pesos, 2.25% of the total expenditure of this branch.

Table 12

BALANCE BY FINANCING SOURCE OF THE ILLNESSES AND MATERNITY FUND						
(data in millions of pesos)						
	Employer Employee Quota	Federal Government Quota	Other revenue a/	Total Revenue	Total Expenditure	Balance
1992	14,092.3	963.4	448.2	15,503.9	16,207.2	-703.3
1993	16,975.3	1,118.8	497.8	18,591.9	19,394.2	-802.3
1994	20,915.9	1,333.1	715.6	22,964.6	22,169.7	794.9
1995	22,799.1	1,474.4	1,090.2	25,363.7	25,747.6	-383.9
1996	28,310.2	1,658.1	1,229.5	31,197.8	32,344.3	-1,146.5
1997 1° Sem.	17,452.4	997.9	575.7	19,026.0	19,121.9	-95.9
1997 2° Sem. *	16,884.0	7,121.4	373.6	24,379.0	22,617.6	1,761.4
1998 b/	38,340.0	17,428.1	2,941.9	58,710.0	57,415.8	1,294.2

The shadowed area corresponds to the New Law

a/ Includes moratory interests, investment products and other incomes.

b/ Includes medical expenses for the pensioned (1.5%) and Family Health Insurance.

Source: Instituto Mexicano del Seguro Social

As a conclusion, there are significant surpluses in the SEM, for the first time in the history of social security in Mexico there are reserves for this branch without cross-subsidies. However, the injection of resources from the federal government does not mean that the allocation of these resources is efficient.

On the other hand, from that same Table, we may find a change in the allocation of the financing sources for the SEM, there was an important increase in the share of the State. During the first semester of 1997, it was equivalent to \$997.9 million pesos, and during the second semester it was equal to \$7,121.4 million pesos. This means that the government increased sevenfold its outlay. Employers and employees reduced their share, in the first semester of 1997 it was equal to \$17,452.4 million pesos, and in the second semester it was equal to \$16,884, so the reduction was only of 3.25%. It can be said that there was not a substitution-effect between the federal government quota and the employer-employee quota, the increase helped to obtain surpluses and to be able to have a reserve fund.

If we analyze the unit costs, there is a slight reduction of real costs as a result of diverse efficiency processes. On Table 13, we can see that during the period 1991-1996 the costs fell in such areas as patient per day and surgical interventions. However, in these areas there is an increase from 1996 and on. The costs of family medicine examinations fell in real terms between 1991 and 1998. Under the New Law we can affirm that between 1997 and 1998 most of the costs are larger in all the levels but they are still smaller than in 1991. For such processes that are intensive in complex equipment and expensive drugs, such as specialty consultations, and second and third level surgical interventions, real costs grew from 1991 to 1998.

Table 13

		EVOLUTION OF THE AVERAGE UNITARY COSTS							
		(constant prices 1998)							
		1991	1992	1993	1994	1995	1996	1997	1998
Family Medicine Consultations									
	1st level	163	171	166	167	137	119	129	137
	2nd level	176	173	163	167	139	116	132	141
Specialty Consultations									
	1st level	289	305	404	320	210	221	209	210
	2nd level	198	208	228	236	210	190	226	259
	3rd level	295	328	353	391	346	309	345	400
Patient Days									
	1st level	1,772	2,159	2,285	2,197	1,999	1,622	1,872	2,306
	2nd level	1,176	1,326	1,262		1,201	1,053	1,198	1,304
	3rd level	1,221	1,351	1,256		1,283	1,089	1,243	1,369
Surgical Interventions									
	2nd level	3,258	3,257	3,766	3,650	3,086	2,713	3,161	3,359
	3rd level	5,977	6,332	7,934		7,612	6,732	7,625	7,709
Clinic Analysis									
	1st level	27	29	30	30	26	22	24	25
	2nd level	28	29	30	30	24	22	26	27
	3rd level	27	26	27		24	21	24	26
Radiodiagnosis Studies									
	1st level	60	64	60	61	54	48	56	56
	2nd level	89	95	92	94	83	77	95	94
	3rd level	127	142	138		126	108	131	130
Births and Abortions									
	1st level	107	142	130	152	79	50	78	-580
	2nd level	1,769	1,967	1,856	1,636	1,515	1,369	710	1,850

Source: Instituto Mexicano del Seguro Social

With the data provided above, it is worth noting that the increasing government outlays relieved the scarcity of resources inside the IMSS that was beginning to have an effect on the quality and reliability of attention. Still, the Institute did not abandon the basic reform strategies such as the cost containment from more efficient processes especially that intensive in labor.

The growth in health costs is caused by the technological changes and the excessive expenditure in the use of diagnose assistance and treatment, processes that the IMSS controls by the use of basic lists, and protocols for drugs prescriptions and clinical treatments.

The *Convenio de Fortalecimiento Financiero*¹²⁹ strengthens the financial restructure of the Institution because it wanted to manage in a desconcentrated way the resources only if they can maintain the financing scheme without deficits in the next section we will give a thorough explanation of this agreement.

As a conclusion, the financial restructure was instrumented on time, it generated surpluses because of the increasing share of the federal government that allowed the Illness and Maternity Fund to have reserves without any cross-subsidies. This situation has a legal organizational and

¹²⁹ This program has a detailed actuarial evaluation of the SEM as well as policy recommendations.

administrative background that guarantees its establishment. All the technical preparations have been covered, and a cost control policy has not been abandoned so there is a favorable background that helps develop the changing projects that the reform needs. However, the financial reform is not finished yet.

B. Desconcentration and Regionalization of The IMSS

The PRSS found as centralism problems: the low efficiency concerning the orientation of resources, the low definition of responsibilities, the bureaucratism involved in the decision making that delays actions and processes, and the obstacles for the performance of the second and third level units. In the IMSS Diagnosis¹³⁰ among the main problems found were the excessive centralism: the normative rigidity and the gigantism of the Institution. At the same time, purchasing was centralized so the Institute did not answer on time and in form to regional or local necessities. The way to solve these problems was the regional division of the Institution.

In 1995 and 1996 seven regions were established in order to systematize decision making between the 37 delegations and the normative center.¹³¹ In 1998 the purchasing of equipment and drugs was desconcentrated into each of the regions.

The regional division of the IMSS was integral and well timed, however the following obstacles can be observed: the regional directives have a trend of reproducing the central normative scheme and increase their structures.¹³² Moreover, they present conflicts between the authority and the center, the region and the delegation.¹³³ On the other hand, a better technical preparation is needed among the regional management authorities and their middle status managers, so the Programa de Fortalecimiento Gerencial (Managerial Strengthening Program) has to be considered in a more active way.

In order to complete the financial autonomy of the IMSS, there was a Convenio de Fortalecimiento Financiero (Financial Strengthening Agreement) among the Ministry of Finance, the Ministry of

Comptrollership (SECODAM) and the IMSS that was signed in October 1998. With this, there is a legal base that guarantees financial viability and autonomy. Furthermore, a policy of savings was generated and the creation of reserves to obtain stability in the quality of services with efficiency and opportunity that would generate administrative simplification between the IMSS, the Ministry of Finance and SECODAM.¹³⁴

The settlement established in this agreement for the enhancing of health were: training within the directors, introduction of medical management systems, the generation of a data base that would include the Single Code of Population Registration (CURP), the introduction of

¹³⁰ The *Diagnóstico* was published in 1995, and it wanted to analyze thoroughly the situation inside the IMSS.

¹³¹ The delegations are organizational entities with legal faculties for affiliation, collection and other economic-financial and medical actions, so there was a crisis of authority as well as duplicity of functions between the region and the delegation so that is why an analysis of the organizational design was needed.

¹³² The main disadvantage if the IMSS in economic terms is the high weight of its corporate or administrative instances so regional structures have to be limited in their growth.

¹³³ An example is the purchasing of medicines that generated conflict between the three entities, because it was not clear where to separate and where to apply its economies of scale.

¹³⁴ IMSS, (1998) *Programa y Convenio de Fortalecimiento Financiero 1998-2000*. Versión Ejecutiva. México: IMSS. November. Pp. 15.

systems that classify patients by diagnostic-related groups, and the improvement of the supplying system among others. It is worth noting that there are three out of seven Financial and Budget Strengthening Agreements that have been signed between the central authority of IMSS and the delegations, the commitment is to have by the year 2000 all the agreements signed.

Due to the budget uncertainty it was necessary to elaborate the legal background with financial ceilings of medium term in the regional and delegational levels in order to desconcentrate and separate financing from delivery services. In 1998, there were 139 Medical Areas of Desconcentrated Management (AMGD). This materialized a greater level of desconcentration and by the year 2000 the commitment is to have all the agreements signed.

C. Institutional Model for Comprehensive Health Services (MIAIS)

The main problems detected in the present model are the need to structure a direct attention model of institutional medical practice that would synthesize the actions of the reform that would guarantee integral attention with quality and efficiency that would solve the following demands: new cost-efficiency models in the family practice, the provision of other social services, hospitals, community health, workplace safety, under a context of financial desconcentration and technical autonomy; a real separation between financing and delivery of services that would lead to competition among providers in order to diminish the inefficiencies; a reengineering of processes to increase the effectiveness and the definition of unit costs of attention. The economic incentives of performance would generate a better quality in the delivery of services. The MIAIS was designed the solution of this problems.

In January 1998, the First National Reunion for Medical Zones took place but the strategy was halted for another negotiation with the union. In September, the final version of the document was presented, the document that would lead the reform in the health component was called Institutional Model for Comprehensive Health Services (*Modelo Institucional de Atención Integral a la Salud* MIAIS). An integral attention in the areas of social services, community health, family health and hospitalization; the coverage of the Desconcentrated Management Medical Zones; the determination of health necessities by the Daily Annual Life Years Adjusted (DALYS) methodology; the use of the methodology for cost of health services by diagnostic-related groups (DRGs).

On the other hand, a credit of the World Bank was signed for \$700 million US dollars to solve the existing lag and obsolescence of the surgical and medical equipment, and another credit for \$25 million US dollars to develop strategic projects of technical assistance that would materialize the process of change.

The IMSS has the commitment to design an investment fund that will maintain the surgical equipment and guarantee the existence of resources. The problem is that by 1999 the reform of the health component has not started, because in the best case some of the projects are in the design or pilot phase so time is the mayor obstacle. The delay in implementation can be understood because of the need to continuously reinforce the actual efficiency and modernization processes, and the union delayed the implementation of the project of medical areas, among this one of the most important issues of the reform. Furthermore, the World Bank credit will be used to accelerate the reform process even though it only has two years in the present administration to design, pilot and give recommendations with hard data to establish new processes.

D. Medical Areas of Desconcentration Management (AMGD)

In order to respond to the local needs of health, it is necessary to restructure the services given by the IMSS. As a precedent to regionalization it can be observed that in 1982 the IMSS structured its services in regions and zones, so a referral system was instrumented, there is a way to refer patients to different levels of attention. Nonetheless, due to the growth of the medical infrastructure and the incorporation of new technologies it was necessary to bring up to date the division of zones. A new organization of the service structures that would allow a desconcentrated management of the resources and an integration of local networks of first and second level providers for specific geographic areas.

In 1997 the project for medical zones was developed, however it was not accepted by the union because it was not negotiated from the beginning with them and its structure was affected. The project was consensed during 1998 with the union, the project was changed into the Medical Areas of Desconcentrated Management (AMGD), these areas are defined by their demographic and epidemiological characteristics and the local capacity to respond to certain problems inside the IMSS.¹³⁵

From the reform proposal (1999-2000) it can be noted that there was a commitment to structuring 139 AMGD by the end of the year 2000 in order to have a structure with better economies of scale, and economic and technical desconcentration. Furthermore, there are three out of seven Financial Strengthening Agreements signed, in these the region and the delegation are formally committed to develop management agreement with the AMGD.

This project has been designed, though the problem is the risk of inserting a new Desconcentrated zone structure by the end of the administration. It has been questioned that the President of the Executive Committee for the Administration of the Area is the general director of the hospital inside the AMGD, because he/she would privilege the hospital over the non-hospital primary health care centers. Also, the medium level personnel is not prepared to assume managerial functions and the innovative programs that will be used in the AMGD for Social Rendering and Community Health are not designed yet, as well as the economic and financial model.

Only the first steps of this process have been covered and the AMGD model in the operative aspect is about to be built so its possibility for consolidating is low. However, the British experience shows that it is better to take the decision of decentralizing even if the conditions are not in an optimum level, otherwise the process is always delayed and never gets there.¹³⁶

The following IMSS administration will have a more desconcentrated structure and more financial autonomy but it will have to continue the process.

E. Family Health Insurance (SSF)

There are problems about the ways to get health insurance by prepaid systems, specially for those workers in the informal sector of the economy. These problems are mainly caused by the high cost that represents a private health insurance for a family. Notwithstanding, since there are no options for the uninsured population, the IMSS has fraudulent incorporation when the

¹³⁵ The AMGD have at least one Zone General Hospital or a Regional Hospital, Sub-Zone Hospitals, Family Medicine Units and Social Rendering, and Community Health of its influence area.

¹³⁶ About the British case see Robinson, R & Le Grand, J. (1994) *Evaluating the NHS Reforms*, Newbury: King's Fund Institute.

population has to get expensive treatment and does not have an insurance. The instrument that was designed to provide prepaid services for the informal sector by voluntary incorporation that would not become as expensive as the private insurance and that would make all the IMSS services available to all, is the Family Health Insurance.

In 1996 the first strategy wanted to cover all the families that were outside the social security.¹³⁷ The legal requirements were to create a Regulation of the Family Health Insurance,¹³⁸ where the coverage is specified, the head of the insured family and his/her legal beneficiaries that would be his economic dependents.

The federal government will pay an additional share equivalent to 13.9% of the minimum wage. However, there is an economic barrier for the incorporation of the families: the amount established for the insurance that is equivalent to 22.4% of the annual minimum wage,¹³⁹ and has to be paid in advance and in one payment.

By January 1999, a total of 199,143 heads of the family were incorporated to this insurance scheme, so if we consider an average family of five members it would imply that almost 1'000,000 people are covered. The SSF is the most cost-effective option to get affiliated to a prepaid system with an integral coverage.

On Table 14, it can be observed that if we consider the last trimester of 1998, the annual cost of the SSF was of \$2,578.00 pesos per family, while a private health insurance would cost in an average \$5,459.00 pesos per person. On the other hand there is also a Collective Facultative Insurance that had a cost of \$1,512.00 pesos and the Individual Facultative Insurance had a cost of \$1,846.00 pesos.

Table 14

ANNUAL ESTIMATES OF THE COST OF THE MEDICAL INSURANCE				
	Trimesters*			
	1	2	3	4
Facultative Insurance (Individual)				
1995	954	1,068	1,068	1,104
1996	1,180	1,228	1,323	1,398
1997	1,549	1,549	1,549	1,549
1998	1,768	1,768	1,768	1,846
Facultative Insurance (Collective)				
1995	782	875	875	905
1996	966	1,006	1,084	1,145
1997	1,269	1,269	1,269	1,269
1998	1,448	1,448	1,448	1,512
Family Health Insurance				
1997	0	0	2,163	2,163
1998	2,469	2,469	2,469	2,578
Private Insurance				
1995	2,294	2,294	2,294	2,497
1996	2,902	2,966	3,373	4,079
1997	4,452	4,802	4,802	4,802
1998	5,459	5,459	5,459	5,459

* Data in Mexican pesos
Source: Instituto Mexicano del Seguro Social

¹³⁷ IMSS, (1996) *Lineamientos Estratégicos 1996-2000*. México: IMSS. Pp. 25.

¹³⁸ IMSS, (1997) *Reglamento del Seguro de Salud para la Familia*. México: IMSS.

¹³⁹ Mexico City urban area.

The Facultative Insurance was designed for certain political or economic organizations, so the Institute has to keep this instrument. The Individual Facultative Insurance is voluntary fee related to in kind benefits for people who leave their jobs and want to keep their social insurance. We can conclude that only the SSF can be compared to a private insurance and that the first is a better cost-effective option.

On Table 15 the voluntary contributions of the Individual Facultative Insurance decreased from 180,000 in 1991 to 101,000 in 1998, the Collective Facultative Insurance increased only in 2.3%, going from 152,000 in 1991 to 155,857 in January 1999, meanwhile the SSF in two years has 199,143 tutors.

Table 15

DEVELOPMENT OF THE FACULTATIVE INSURANCE (1991-1998)								
(data to December in thousands)								
	1991	1992	1993	1994	1995	1996	1997	1998
Premanently Insured Workers								
Urban	8,631	8,596	8,426	8,579	8,219	8,864	9,555	9,845
Rural	375	322	305	290	284	299	283	296
Total	9,006	8,918	8,731	8,869	8,503	9,163	9,838	10,141
Eventually Insured Workers								
Building Insustry	805	858	854	866	466	603	386	537
Non Building Insustry	276	233	218	218	164	192	328	633
Rural Seasonal	203	173	198	185	190	185	202	196
Total	1,284	1,264	1,270	1,269	820	980	916	1,366
Total Workers	10,290	10,182	10,001	10,138	9,323	10,143	10,754	11,507
Non Workers Insured								
Voluntary Continuations	180	193	200	203	209	233	224	101
Facultative Insurance	152	145	207	226	202	194	221	350
Students	712	848	911	995	1,199	1,326	1,515	1,653
Total non workers	1,044	1,186	1,318	1,424	1,610	1,753	1,960	2,104
Total insured	11,334	11,368	11,319	11,562	10,933	11,896	12,714	13,611

Source: Instituto Mexicano del Seguro Social

It is important to note that the SSF has been criticized because of its low diffusion and visibility. This could be due to saturation of the medical services or since the main intention of the reform was to increase coverage in the obligatory regime in order to guarantee social integral protection to workers and their families. Furthermore, the SSF could be used as a fraudulent source of insurance since the employees could agree with the employers only to have a SSF instead of the integral coverage of the IMSS that includes work hazards and pensions.

Notwithstanding, there is also an excessive regulation for the entrance to the SSF, so it is not as attractive for the population. The Illness and Maternity Fund allows anybody with a formal job to get this kind of coverage, so fraudulent incorporations and adverse selection are set in this insurance, persons needing treatment can always find someone that affiliates them to the IMSS.

The Family Health Insurance could be promoted in a collective way so that governors of the states, in the context of New Federalism and using the new faculties that they have in the Health Sector, could buy the insurance for the uninsured population and those population groups who cannot pay the premium and have access only to the inefficient public assistance health services. In some states the governments are studying this with the IMSS as an option.

F. Family Doctor Eligibility and Performance Incentives for Family Health Centers

The main problem at the first level of attention that the IMSS has is related to the quality of the attention generated to the absence of choosing the family doctor. Furthermore, the physician does not have career incentives to improve performance that would make him/her keep track of his/her patients. A new remuneration system is needed in order to eliminate the salary remuneration that is bureaucratic and requires the introduction of performance incentives, that would pay more to the effort made. The model proposed to solve this problem is known as the new model of family medicine with eligibility of the family doctor by the consumer.

According to the 1995 Health Sector Reform Program, the users should be able to choose the physician and with this, increase the quality of attention. The IMSS proposed the development of the *Nuevo Modelo de Medicina de Familia*¹⁴⁰ (New Model of Family Medicine). This model has the objective of strengthening the health attention for first level users with a model that incorporates processes, develops work teams and that gives integral services with quality, efficiency and opportunity, with the commitment of the IMSS workers.

The model wants to rise the solving capacity of first level of attention, offer continuous medical attention, integral health attention, eligibility of the family practitioner and performance incentives. The incentives of this model are by capitated weight, incentives by accomplishment of quality factors and incentives by research done. The family physician would have an extra payment besides his salary by the number of users that would choose him, in other words, by a capitated payment integrated to his/her salary.

The union conditioned the project so that all the workers in a Family Medicine Unit and not only the physician and his/her team would have access to this incentives system. The project was renegotiated and it was approved in 1998 by the union only if the Institute for Union Studies and Social Security would evaluate the pilots made in 37 units.

The model of eligibility with performance incentives has an important delay in its implementation, and it is only being piloted at the moment. One of the obstacles is that there is a system needed as well for hospitals, and this one has not been designed so it is impossible to generalize if this situation is not solved.

The model is totally designed and is an innovation in the presentation of health services in Mexico. A pilot has been programmed in 37 units for 1999, even though the union is hesitant.

G. Performance Incentives

One of the main problems of the Health Sector Reform Program is the absence of performance incentives which has negative effects in the quality of services. The incentives scheme for the new model of family medicine is already designed, however as we mentioned before, this model cannot be implemented unless another model is designed for hospitals. So a performance incentive strategy is to be designed for hospitals, research and development centers, centers for social security, health at work, medical support areas and administrative areas. However, a system of performance incentives for IMSS workers was proposed. The Institute reached an agreement with the union in which the Institute for Union Studies and Social Security, created in 1999, will develop this system.

¹⁴⁰ IMSS, (1998) *Modelo de Medicina de Familia*. Documento para prueba. México: IMSS.

The commitments of reform for 1999-2000 show the need to design a pilot in order to obtain the System for Performance Incentives for Workers in the Health Area (SINDAS).¹⁴¹

Furthermore, a performance incentive system has to be developed and piloted for other health centers that are not hospitals or medical family units.

In relation to the speed, it can be noted that this program is only in its design phase for the hospital incentives system, and for the other health components. The administration will finish before the system goes beyond the design phase so it has the risk of not being formally established. The project has to be approved by the union because it conditioned the project to the non-alteration of the activities that each worker has established in the General Work Contract.

H. Costing According to Diagnostic-Related Groups (DRGs)¹⁴²

One of the main problems of the IMSS is that it does not have the information about unitary costs in order to separate financing from delivery of services. Moreover, there are no reliable guidelines for evaluation of when it is optimal incur in outsourcing of services and when to provide them directly. It is necessary to have this information in order to be able to charge for these services. In addition, the guidelines are insufficient to evaluate the efficiency of the units and no benchmarking systems can be adapted if there is no cost information. Due to this, internationally proved methodologies have to be adapted to obtain costs, such as Diagnosis-Related Groups so the costing processes have to achieve a quality norm that guarantees and keeps the health of the users and the safety of the workers.

In 1996 the IMSS decided to adapt the methodology of Diagnosis-Related Groups in order to obtain costs of its processes. Since 1997 the first patient classification studies were made by this method. In 1998 national reunions took place to obtain the production function in each of the DRGs by a call of national experts. At the same time, the commitment of the adoption of the methodology of DRGs is established in the Managerial Strengthening Agreement.

The commitment for 1999-2000,¹⁴³ is that with the credit of the World Bank technical assistance projects will be financed so that the IMSS can recognize its own costs and has a norm for its processes based on the different cases each method has. The classification of patients in 216 second level hospitals and 41 third level hospitals. Furthermore, a project will be designed for the definition of protocols for 500 DRGs, where the form by which the medical processes in the IMSS and the type of resources that are consumed.

One of the challenges is that in sixteen months the system has to be built, the processes transformed, the DRGs implanted, the information systems installed and the training of the staff done. The problem is centered on the timing, since the DRGs are in the experimental phase and it will be very hard to see this as a methodology for the administrative and medical staff inside

¹⁴¹ The objectives of the System for Performance Incentives in Hospitals are: a) To elaborate a "Situational Hospital Diagnose" for the structuring of a incentives system; b) define the "Structure of the Performance Incentives System in Hospitals"; c) define the "Financial and Economic Model" of the system; d) propose experts for the developing of software and for the design and implantation; e) design and implantation of the software; f) design and implant the "Training Program"; g) Implant the system in its different components, and h) elaborate a "Performance Incentives Program" for medium term.

¹⁴² The GRD is a classification technique that orders different episodes in the medical attention inside the hospitals, and it is according to the use of resources in the diagnosis and therapeutic management of patients.

¹⁴³ See note 22.

the IMSS. Furthermore, the possibility of changing the information systems and developing the costing system and training of the GRDs should be integral and it is a very short time to be able to generalize before the year 2000.

I. Contracting Out of Health Services¹⁴⁴

The comprehensive contracting out of clinical services is a scheme that already represents 2.5% of the total IMSS affiliates (around 200,000 workers), of which 95% are in the banking sector.

The main problems for the development of a comprehensive strategy of contracting out clinical services are that the health services provided directly by IMSS are perceived as being of a low quality. Some insured people prefer to solve their health demands in the private sector with out-of-pocket payments or by purchasing a private health insurance. Furthermore, some firms compulsory enrolled in IMSS offer their workers a private insurance so the problem of double quoting arises.

Moreover, it is hard for a firm to get into the comprehensive contracting out system since it has been more than 10 years that no new agreements for private firms have been authorized to do it. Up until now the Technical Council of the IMSS has the discretionary option to determine which firm has all the requirements to participate in this scheme. The result is an unclear process and until now the requirements and the circumstances under which a firm can have access to this agreement are not crystal-clear.

Besides, the present comprehensive contracting out scheme the IMSS has the following characteristics: a) the already signed agreements do not have the same format, they are heterogeneous in relation to the kind of services that they offer and the amount of money to charge, b) the amount to charge or percentage of quota to revert to the firm, apparently is not based on the cost of services, c) the scheme is focused to a curative system, d) there is no eligibility of the service provider by the worker, and he/she has to follow his/her firms agreement with the doctors, e) they do not provide statistic information to the IMSS, even though their workers are still IMSS-insured, f) the quality and the costs are not regulated, g) competition is not regulated either, h) it is not adjusted by risk.

The form proposed to solve this situation consists in the development of a new scheme based on pool risk for at least 100,000 people with a per capita cost according to age and sex that provide comprehensive and integral health care.

During its early stages, the draft amendment to the Social Security Law included a clause that would guarantee a more systematic and transparent process to approve quota reimbursements to those firms who complied with IMSS requirements to cover the health services of their employees. This proposal proved to be politically contentious and was eventually discarded during negotiations in the Lower Chamber. The IMSS Directive was aware that the previous Law did provide for these type contracts, and that therefore there was enough room for manouvre for the IMSS administration to continue to manage the process of quota reimbursement via administrative acts or contracts, at the speed and scope it considered pertinent and on a case by case basis.

¹⁴⁴ The quota reversion in health services is the mechanism by which the employer is responsible of the provision of health services to his/her employees and their beneficiaries. Its nature and quality is similar to the services given by the IMSS, the Illness and Maternity Branch and Risk at Work Branch. Part of the employer-worker quota is given back because of the corresponding branches.

Further more, as of 1996, the employer-employee quota share for the Illness and Maternity Fund was greatly reduced as a result of the New Law, while the government's share augmented significantly. This adjustment, which became a substantive subsidy from public funds to the production sector, reduced the business community's incentives to press for a quota reimbursement scheme due mainly to two reasons. Firstly, because the reduction in quotas diminished the pressure on production costs – as was the policy makers' goal -, and thus the issue ceased to be on their agenda. Second, because if quota reimbursement was to be obtained, employers would only receive an amount equivalent to their contribution, which would not be enough to cover the costs of the health services they would have to grant their employees in order to qualify for it. This issue is still under study and discussion both in the public and in the private sectors, with part of the business community pressing to have part of the government's share devolved as well to the qualifying businesses.

In light of this stalemate, a new proposal of integral and comprehensive contracting out of clinical services is currently being analyzed. It consists firstly in the separation of the financing from the delivery of services in such a way that the employer could still pay the totality of his/her quotas to the IMSS. The IMSS would have agreements for the provision of comprehensive and integral health services with Health Management Organizations (HMO's). Second, a "risk pool" or a "risk fund" had to be generated, where a certain capitated value should be given to each insured person according to his/her sex, age, and average expenditure in the IMSS among other variables. Third, the firm should offer an integral package of health services that would be the same in nature, kind and quantity to the one given by the IMSS and in exchange he would receive a capitated payment. Fourth, the OASS will establish agreements with service providers, if they have a certification of the National Insurance and Bail Bonds Commission (CNSF).

The main problem was the opposition of the union to any kind of participation of the private sector, including the contracting out of services, because it saw it as a precedent to the IMSS privatization. Furthermore, the capacity of response of the private sector was questioned due to the fact that 85% of the private hospitals are micro firms with less than 15 beds with lack of capacity to respond to complex demands. Moreover, there were very few HMOs in Mexico and there was the absence of an insurance culture within the Mexicans. The project was suspended.

The Executive sent in April 1999 an initiative to the Lower Chamber to reform the General Law of Mutualist Insurance Societies and Institutions, in which the health services that these institutions will provide will be added to the medical expenses insurance. This law was approved by the Lower Chamber and the Upper Chamber will discuss it. The proposal establishes the framework in which the insurance companies will increase their participation in the private medicine business without modifying the actual regulating laws of social security.¹⁴⁵

The HMOs will have to be regulated as insurance companies to be supervised by the CNSF. The new scheme has technical problems to be solved, such as the one of giving the HMOs the constitution of an insurance company. With this, costs increase because they need reserves and have to comply with all the technical and economic norms that any insurance company has to comply with.

With respect to the administrative requirements, the IMSS had the commitment since 1996 to elaborate the Regulation of the contracting out of clinical services, which has not been concluded. Notwithstanding, it is necessary to regulate the market of prepaid private providers of

¹⁴⁵ The CNSS is proposed to act in a coordinated way with the Ministry of Health in order to obtain an integral vigilance of the institutions that have the authorization to operate in the health sector. The SSA will emit technical opinions to support the participation of the institutions and will supervise them.

health services and to develop a scheme of integral subrogation of health services within the IMSS.

However, the private health services attention in Mexico has been regulated in a very loose manner, because of market imperfections, prices are very high. The financing scheme in the sector is basically out-of-pocket payments. The health insurance only covers 2.4% of the total population of the country.

It will be difficult to expand the private provision of health care. The IMSS will not subsidize the private sector and the integral comprehensive contracting out of clinical services has to be mediated by the costs of attention of the IMSS. Which are low compared to those in the private sector, because of the economies of scale, payment methods based on salaries and not by event, and the regulations to the incorporation of new technology such as the basic schemes.

As a conclusion, it can be observed that although there are formulas designed to solve this component of the reform there has been no advance on these issues. There is no new agreement for the contracting out of clinical services (quota reimbursement), and there has not been an answer to the absolute decrease in the share to revert used to fund health services in the actual quota reversion scheme. However, no new spaces have been created for the participation of the private sector in the integral comprehensive contracting out of clinical services scheme.

IV. CONCLUSIONS

The following remarks about the reform of the health component of the IMSS and its characterization will be based in what was about the socio-economic context, as well as the conclusions found in the policy tracers.

Given the depth of the economic crisis in 1994 and the restrictive policies that followed in response, the reform of the health sector lost its priority in the public agenda, limiting it to remedial policy changes and significantly slowing its pace. All the government efforts were focused on restoring the macroeconomic equilibrium. However, due to the importance of pensions reform as part of this response in the maintenance and support of high government spheres and could thus be passed through the Upper and Lower Chambers.

The absence of political will to support the health sector reform, since it only had four general strategic lines, was due to the absence of defined proposals.

The health system is still segmented and has great differentials of per capita expenditure among public provider institutions. Also, the overlapping among target groups has not been solved. The poorest do not have guaranteed access to basic health care services and are more exposed than other groups to catastrophic expenses. It is worth noting that mid and high level income groups are also exposed due to the low coverage of the private insurance and prepaid systems. Furthermore, before the economic crisis, 40% of the resources of the health care system in Mexico came from out-of-pocket payments. Due to the crisis, that fund increased to 64% by 1995. This means that from all the money used for health care, two thirds were used to satisfy the demands of attention through out-of-pocket payments.¹⁴⁶

It can be concluded that the reform of the IMSS was not supported by a process of overall policy change in the health sector as a whole - that would include significant changes in the

¹⁴⁶ It is recommended to have this fund decrease to 10% and direct the other 50% through prepaid systems.

Ministry of Health as well, among other health provider institutions. The IMSS developed a separate reform process aimed at solving the strategic problems that have been presented in this chapter. However, the elements of this internal process of reform were discussed and formally presented as part of the national health sector reform program – thus rising expectations of a comprehensive and integrated reform. The IMSS reform consisted mainly in the restructuring of all its insurance branches. A pension funds system was created independent of other IMSS accounts and managed by the private sector. The Institute had to further its reform in order to make other branches that previously counted on cross-subsidies from pensions funds, self-sufficient and thus prevent future deficits. Since this changes affected primarily the health component of IMSS, equity and service quality were also incorporated to the health reform agenda. The financial restructuring, along with a significant increase in the government's outlay, restored IMSS actuarial equilibrium. Simultaneously, new insurance branches were created in order to offer prepaid systems financially accessible to the informal sector workers, and for the self-employed. However, there are still serious income and procedural barriers; which, along with a low level of diffusion, have not made this type of insurance a complete success. The Institution has financial certainty, which is added to the desconcentration process and the generation of autonomy. Decentralization was taken to the local level as well as the financial desconcentration with the techniques and design of new tools for the reform. However, most of these new techniques and tools are in the pilot phase. The participation of the private sector and outsourcing of services have proposals in the strategic areas of the reform that are also in the design phase.

The structure of remuneration of the workers is being changed in order to improve the quality and technical efficiency of the attention processes. Furthermore, the IMSS got external resources in order to solve the problem of obsolescence of the medical equipment and for the development of technical assistance problems for the institutional strengthening in the different levels of attention and thus prepare them for the implementation of the reform. As a critical aspect, the worst obstacle the reform faces is the timing, since most its components are currently in design or pilot phase, and the change of the administration is due in December 2000. The reform's continuity and eventual consolidation will be entirely dependent on the political will of the following administration and the socio-economic context in which it evolves.

In synthesis, and as a general conclusion, the IMSS reform was supported in the beginning by the federal government in its financial component. However, this initiative was not followed by a reform process in the health sector as a whole. There is an internal proposal that is considered integral but it is still in its first phase - design and pilot – and it is very vulnerable because it will not be completely consolidated before the change of administrations.

BIBLIOGRAPHY

I. POLITICAL ECONOMY CONTEXT

- Aguilar García, Javier, "Los sindicatos nacionales" in El obrero mexicano, organización y sindicalismo, 3, Siglo XXI, México, 1986.
- Aguinaco Alemán, José Vicente, "La Reforma al Poder Judicial de la Federación 1994 – 1995" in La Justicia Mexicana: Hacia el Siglo XXI, UNAM y Senado de la República LVI Legislatura, México, 1997.
- Alcocer, Jorge; Cordera, Rolando, et al., México: Presente y Futuro, Ediciones de cultura popular, México 1985.
- Anguiano, Arturo, El Estado y la política obrera del cardenismo, Ediciones Era, México, 1982.
- Ayala Espino, José, Estado y desarrollo, la formación de la economía mixta mexicana (1920-1982), Fondo de cultura económica, México, 1988.
- Bailey, John, "Centralism and political change in Mexico: The case of national solidarity" in Wayne A. Cornelius, Ann L. Craig and Jonathan Fox (eds.), Transforming State-Society Relations in Mexico: the National Solidarity Strategy, San Diego Center for U.S.- Mexican Studies, University of California, 1994.
- Bailey, John, "Presidency, Bureaucracy, and administrative Reform in Mexico: The Secretariat of Programming and Budget", in *Inter-American Economic Affairs*, Vol. 34, No. 1., 1980
- Bailey, Norman y Richard Cohen, The Mexican time bomb, Twentieth Century Fund Paper, Priority Press Publications, New York, 1987.
- Bennett, Douglas y Kenneth Sharpe, "The state as banker and entrepreneur: the last resort character of the Mexican state's economic intervention, 1917-1970" in *Inter American Politics Series*, Vol. 3, 1984.
- Bensusán, Graciela, "Constitución y desarrollo del derecho laboral mexicano", in El obrero mexicano, el derecho laboral, IV, UNAM, Siglo XXI, México, 1985.
- Bravo Mena, Luis Felipe, "COPARMEX and Mexican politics" in Sylvia Maxfield y Ricardo Anzaldúa, eds., Government and private sector in contemporary Mexico, University of California, Center for U.S.-Mexican Studies, San Diego, 1987.
- Camacho, Manuel, La clase obrera en la historia de México, el futuro inmediato, UNAM, Siglo XXI, México, 1980.
- Camp, Roderic Ai, "The Political Technocrat in Mexico and the Survival of the Political System", in *Latin American Research Review*, Vol. 20, No. 1., 1985.
- Camp, Roderic Ai, La Política en México, Siglo veintiuno editores, México, 1995.
- Camp, Roderic Ai, Politics in Mexico, Oxford: Oxford University Press, Oxford, 1993.
- Carlos Sirvient, La burocracia, Anuies, México 1977.

- Carrillo Aronte, Ricardo, "The role of the state and entrepreneurial sector in Mexican development" en Sylvia Maxfield y Ricardo Anzaldúa, eds., Government and private sector in contemporary Mexico, University of California, San Diego:Center for U.S.-Mexican Studies, 1987.
- Centeno, Miguel Angel, Democracy within reason, technocratic revolution in Mexico, Pennsylvania State University Press, Pennsylvania, 1994.
- Constitución Política de Los Estados Unidos Mexicanos, Editores mexicanos unidos, 1999.
- Córdoba, Arnaldo, La ideología de la revolución mexicana, Ediciones Era, México, 1970.
- Córdoba, Arnaldo, "La concepción del Estado en México y el presidencialismo" in Pablo González Casanova (coord.), El Estado en América Latina, Teoría y práctica, México: Universidad de las Naciones Unidas y Siglo veintiuno editores, México, 1990.
- Cornelius, Wayne A., Ann L. Craig and Jonathan Fox (eds.), Transforming state society relations in Mexico: the National Solidarity strategy, Center for U.S.-Mexican Studies, University of California, San Diego, 1994.
- Cornelius, Wayne y Ann Craig, Politics in Mexico: an introduction and overview, Center for U.S.-Mexican Studies, University of California, San Diego, 1988.
- Cornelius, Wayne, Gentleman, Judith and Peter Smith, "The dynamics of political change in Mexico", in Wayne Cornelius, Judith Gentleman y Peter Smith (eds.), México´s alternative political futures, University of California, San Diego: Center for U.S.-Mexican Studies, 1989.
- Domínguez, Jorge I, Technopols, freeing politics and markets in Latin America in the 1990´s, Pennsylvania State University Press, Pennsylvania, 1994.
- Dresser, Denise "Bringing the poor back in: National Solidarity as a strategy of regime legitimation" in Wayne A. Cornelius, Ann L. Craig and Jonathan Fox (eds.), Transforming State-Society Relations in Mexico: the National Solidarity Strategy, San Diego Center for U.S.- Mexican Studies, University of California, 1994.
- El Herald de México*, 9 de abril de 1985, p. 1.
- Escobar Toledo, Saúl "Rifts in the mexican power elite, 1976-1986" in Sylvia Maxfield y Ricardo Anzaldúa, eds., Government and private sector in contemporary Mexico, University of California, Center for U.S.-Mexican Studies, San Diego, 1987.
- Flores de la Peña, Horacio, Teoría y práctica del desarrollo, Fondo de Cultura Económica, México, 1976.
- Flores Olea, Victor, "Poder, legitimidad y política en México" in El perfil de México en 1980, Siglo XXI editores, México, 1983
- Frank Brandenburg, The making of modern Mexico, Englewood Cliffs, Prentice Hall, N.J., 1964.
- FUNSALUD, La dimensión política en los procesos de reforma del sistema de salud, Economía y Salud, Documentos para el análisis y la convergencia No.13, Fundación Mexicana para la Salud, México, 1995.
- González Casanova, Pablo, La Democracia en México, Ediciones Era, México, 1967 (1965).
- González Casanova, Pablo, El Estado en América Latina, Teoría y Práctica, México: Universidad de las Naciones Unidas y Siglo veintiuno editores, México, 1990.

- Haggard, Stephan; Kaufman, Robert, "Estado y Reforma Económica: La iniciación y consolidación de las políticas de mercado", in *Desarrollo Económico*, Vol. 35, No. 139, 1995.
- Hernández Rogríguez, Rogelio, "¿Del corporatismo a la contienda electoral?", in Matilde Luna y Ricardo Pozas (coords.), Relaciones corporativas en un período de transición, México: UNAM, Instituto de Investigaciones Sociales, México, 1992.
- Jeichman, Judith A., Privatization and political change in Mexico, University of Pittsburgh Press, Pittsburgh, 1995.
- Kaufman, Robert, The politics of debt in Argentina, Brazil and México, University of California, Berkeley: Institute for International Studies, California, 1980.
- Kaufman, Robert, The politics of debt in Argentina, Brazil, and Mexico: Economic stabilization in the 1980's, University of California, Institute of International Studies, Berkeley, 1988.
- Kuczynski, Pedro Pablo, "Latin American debt: act two", in *Foreign Affairs*, Vol 62, No. 1, 1983.
- Kuczynski, Pedro Pablo, "Latin American debt" in *Foreign Affairs*, Vol. 61, No. 2, 1982.
- La Jornada*: 20 de agosto de 1986; 2 de octubre de 1986, p. 1; 6 de octubre de 1987, p. 5; 17 de octubre de 1987, p. 23; 16 de diciembre de 1987, p. 3; 5 de octubre de 1987, p. 6; 12 de octubre de 1987, p. 1; 16 de octubre de 1987, p. 7; 8 de abril de 1985, p. 3; 24 de octubre de 1987, p. 1.
- Labastida, Julio "Los grupos dominantes frente a las alternativas de cambio" in El perfil de México en 1980, III, Siglo XXI, México, 1972.
- Labastida, Julio, "De la unidad nacional al desarrollo estabilizador (1940-1970)" in Pablo González Casanova, coord., América Latina: historia del medio siglo, II, Instituto de Investigaciones Sociales, UNAM, Siglo XXI, México, 1981.
- Lajous, Alejandra, (coord.), Las razones y las obras, gobierno de Miguel de la Madrid, crónica del sexenio 1982-1988, IV, Fondo de cultura económica, México, 1985.
- Leal, Juan Felipe y José Woldemberg, "El sindicalismo mexicano, aspectos organizativos" en *Cuadernos Políticos*, 7, Ediciones Era, México, enero-marzo de 1976.
- Leal, Juan Felipe, "Las estructuras sindicales" in El obrero mexicano, organización y sindicalismo, 3, Siglo XXI, México, 1986.
- Lerner de Sheinbaum, Bertha "El corporatismo burocrático" in Matilde Luna y Ricardo Pozas (coords.), Relaciones corporativas en un período de transición, UNAM, Instituto de Investigaciones Sociales, México, 1992.
- López Portillo, José, Mis tiempos, biografía y testimonio político, Fernández Editores, México, 1988.
- Luna, Matilde; Tirado, Ricardo y Francisco Valdés, "Businessmen and politics in Mexico" in Sylvia Maxfield y Ricardo Anzaldúa, eds., Government and private sector in contemporary Mexico, University of California, San Diego:Center for U.S.-Mexican Studies, 1987.
- Mendoza Berrueto, Eliseo El presidencialismo mexicano, Una tradición ante la reforma del Estado, México: El Colegio de la Frontera Norte y Fondo de Cultura Económica, México, 1996.
- Meyer, Lorenzo; Segovia, Rafael y Alejandra Lajous, Historia de la revolución mexicana 1928-1934, los inicios de la institucionalización, XII, El Colegio de México, México, 1981.

- Molinar Horcasitas, Juan y Jeffrey A. Weldon, "Electoral determinants and consequences of National Solidarity" in Wayne A. Cornelius, Ann L. Craig and Jonathan Fox (eds.), Transforming State-Society Relations in Mexico: the National Solidarity Strategy, San Diego Center for U.S.- Mexican Studies, University of California, 1994.
- Newell, Roberto y Luis Rubio, México´s dilemma: the political origins of economic crisis, Boulder: Westview Press, México, 1984.
- Pereyra, Carlos, "Estado y Sociedad" in México hoy, Siglo XXI, México, 1979.
- Proceso*, 507, 21 de julio de 1986, pp. 20-24.
- Puga, Cristina, "Los empresarios ante la nacionalización de la banca" in Julio Labastida, comp., Grupos económicos y organizaciones empresariales en México, UNAM, Alianza Editorial, México, 1986.
- Reyna, José Luis y Olga Pellicer, Historia de la revolución mexicana, el afianzamiento de la estabilidad política, XXII, El Colegio de México, México, 1978.
- Reynolds, Clark W., "¿Por qué el desarrollo estabilizador de México fue en realidad desestabilizador?", Congreso de los Estados Unidos, Audiencias sobre "Los acontecimientos recientes en México y sus implicaciones económicas para Estados Unidos", Washington, D.C., 17 de enero de 1977.
- Rodríguez, Victoria and Peter Ward, "Disentangling the PRI from the Government in Mexico, in *Mexican Studies*, Vol. 10, No. 1, 1994.
- Rother, Larry, "The Northern Connection", *New York Times*, 3 June 1990, sec 3, p. 6. in: Srephanie R. Golob, "Making possible what is necessary, Pedro Aspe, the Salinas team and the next mexican *miracle*", in: Jorge I. Domínguez, Technopols, freeing politics and markets in Latin America in the 1990´s, Pennsylvania State University Press, Pennsylvania, 1994.
- Rubio, Luis y Francisco Gil Díaz, A Mexican Response, Priority Press Publications, New York, 1987.
- Rubio, Luis; Fernández, Arturo (eds.), México a la hora del cambio, Cal y arena, México, 1995.
- Schmitter, Philippe C. and Lehmbruch, G. (eds), Trends Towards Corporatist Intermediation, Sage, London, 1979
- Secretaría de la Presidencia, "Ley de Secretarías y Departamentos de Estado", Manual de Organizaciones del Gobierno Federal, Gobierno Federal, México, 1976.
- Semanario Punto*, 18 de agosto de 1986, pg. 8.
- Sirvient, Carlos G., "La movilidad política sexenal: los secretarios de estado y el presidente de la república, 1958-1975" in *Estudios Políticos*, México, 1975.
- Sol de México*, 19 de enero de 1983, p. 1.
- Tirado, Ricardo y Francisco Valdés, "Businessmen and politics in Mexico, 1992-1986" in Sylvia Maxfield y Ricardo Anzaldúa, eds., Government and private sector in contemporary Mexico, University of California, Center for U.S.-Mexican Studies, San Diego, 1987.
- Tirado, Ricardo y Matilde Luna, "La politización de los empresarios (1970-1982)" in Julio Labastida, comp., Grupos económicos y organizaciones empresariales en México, UNAM, Alianza Editorial, México, 1986.

- Tirado, Ricardo, "Las organizaciones empresariales y el corporatismo empresarial mexicano" in Matilde Luna y Ricardo Pozas (coords.), Relaciones corporativas en un período de transición, México: UNAM, Instituto de Investigaciones Sociales, 1992.
- Uno Más Uno*, 14 de agosto de 1986, p. 7: "Se organiza en el PRI una corriente prodemocrática", 15 de agosto de 1986, p. 1, 4 de octubre de 1986, p.1., , 5 de octubre de 1987, p. 5.
- Valdés, Francisco, "Una aproximación al análisis de las relaciones entre empresarios y gobierno en México, 1970-1976", in Julio Labastida, comp., Grupos económicos y organizaciones empresariales en México, UNAM, Alianza Editorial, México, 1986.
- Villarreal, René, "Deuda externa y política de ajuste, el caso de México" in Stephany Griffith-Jones (comp.), Deuda externa, renegociación y ajuste en la América Latina, FCE, México, 1988.
- Ward, Peter M. "Social welfare policy and political opening in Mexico", Mexico's Solidarity program in comparative context: Demand-based poverty alleviation programs in Latin America, Africa and Eastern Europe", in Wayne A. Cornelius, Ann L. Craig and Jonathan Fox (eds.), Transforming State-Society Relations in Mexico: the National Solidarity Strategy, San Diego Center for U.S.- Mexican Studies, University of California, 1994.
- Weber, Max , Economía y Sociedad, esbozo de sociología comprensiva, tomos I y II, FCE, México, 1969.
- Weldon, Jeffrey A, "El presidente como legislador: las iniciativas del poder ejecutivo en la Cámara de Diputados, 1917-1934", prepared for delivery at the XX International Congress of the Latin American Studies Association, Guadalajara, 17- 19 April, 1997.
- Weldon, Jeffrey A., "El crecimiento de los poderes metaconstitucionales de Cárdenas y Avila Camacho. Su desempeño legislativo, 1934-1946" in *Diálogo y Debate de cultura política*, Año 1, num 1, pp. 12, México, 1997.
- Zapata, Francisco y Ian Roxborough, "Algunos mitos sobre el sindicalismo en México" in *Diálogos*, 6, p.24, El Colegio de México, 1978.
- Zepeda, Eduardo y David Castro, "Solidaridad: ¿Combatiendo la pobreza extrema? In Jacqueline Martínez Uriarte y Alberto Díaz Cayeros (coords.), Federalismo, CNCPAP, UAM, IFE, México, 1996.

II. POLICY PROCESS

- Barranco, Alberto, "Balance General," *Reforma*, 26 de abril de 1999.
- Cajiga, Gerardo, Las verdades verdaderas, en La Jornada Laboral No.59, pag.4, 28 de diciembre de 1995.
- CEDESS, II Reunión Internacional de expertos en Seguridad Social: Reflexiones sobre las Reformas en la Seguridad Social, Serie: Estudios 34, pags. 387, México, 1997.
- CEDESS, Proyecto Aguila, presentación del 20 de diciembre de 1994.
- Cobb, Roger; Ross, Jennie-Keith, and Marc Howard Ross, "Agenda Building as a Comparative Political Process", *The American Political Science Review*, Vol.70, pps.126-138, 1976.
- Dávila, Enrique, "Mexico: The evolution and reform of the labor market" en Sebastian Edwards and Nora Lusting (editors), Labor Markets in Latin America, R.R. Donolley and Sons and The Brookings Institution, Washington, D.C.: 1997.

- De Regil Vélez, José Rafael (coord.), "1988-1994 Ilusión y Desaliento: Balance del Sexenio Salinista", *Análisis de la Realidad Mexicana* No. 19, Centro de Integración Universitaria, Universidad Iberoamericana, México, 1995.
- Diario de debates, Cámara de diputados, Proyecto de decreto que reforma la Ley del seguro social respecto a las administradoras de fondos para el retiro, Dictamen de las comisiones unidas de Trabajo y Previsión social, y de Seguridad Social, México, diciembre de 1995.
- Diario de debates, Cámara de diputados, Iniciativa con proyecto de decreto que reforma el párrafo primero del artículo primero transitorio de la Ley del Seguro Social, Oficio de la Secretaría de Gobernación que se turnan a las comisiones de Trabajo, Previsión y Seguridad Social, México, 28 de octubre de 1996.
- Diario de debates, Cámara de diputados, Iniciativa de Reformas a la Ley General de Instituciones y Sociedades Mutualistas de Seguros, México, abril de 1999.
- Diario de debates, Cámara de diputados, Ley del seguro Social, Discusión del congreso, 12 de diciembre de 1995.
- Diario de debates, Cámara de diputados, Minuta Proyecto de Decreto: que reforma la Ley General de Instituciones y Sociedades Mutualistas de Seguros, México, 28 de abril de 1999.
- Diario de debates, Cámara de diputados, Proyecto de decreto que reforma y adiciona diversos artículos de la Ley del Seguro Social, Dictamen de las comisiones unidas de Trabajo y previsión Social y de seguridad Social, 15 de diciembre de 1994.
- Discurso del presidente Ernesto Zedillo con motivo de la LXXVI Asamblea General Ordinaria del IMSS, 25 de enero de 1995.
- Excelsior*: primera plana, 2 de mayo de 1996.
- Frenk, Julio; Knaul, Felicia, et. al., "La Seguridad Social en Salud: Perspectivas para la Reforma", en Solís S., Fernando y F. Alejandro Villagómez (comp.), La Seguridad Social en México, Lecturas 88, CIDE, CONSAR, y FCE, México, 1999.
- Fundación Mexicana Para la Salud, Economía y Salud, Propuestas para el avance del sistema de Salud en México, Visión de conjunto, México: 1994.
- FUNSALUD en colaboración con Economía Aplicada, S.C., La Reversión de Cuotas del Instituto Mexicano del Seguro Social: Hacia un Modelo Integral, México, 1997.
- García Sainz, Ricardo, "Principia el Desmantelamiento", en *La Jornada Laboral* No.59, pag.2, 28 de diciembre de 1995.
- González Rossetti, Alejandra, et. al., La dimensión política en los procesos de reforma del sistema de salud, Economía y Salud, Documentos para el análisis y la convergencia, no. 13, Fundación Mexicana para la Salud, México, 1995.
- Grindle, Merilee, Challenging the State: Crisis and Innovation in Latin America and Africa, Cambridge Studies in Comparative Politics, Cambridge University Press, 1996.
- Grupo parlamentario del PAN en la Cámara de diputados, Reforma a la Ley federal de Instituciones de Fianzas, México, 28 de abril de 1999.
- Immergut, Ellen M., Health Politics: Interests and Institutions in Western Europe, Cambridge University Press, Cambridge, 1992.
- IMSS, "*Hacia el Fortalecimiento y Modernización de la Seguridad Social*" (mid 1995).

- IMSS, *Diagnóstico*, marzo de 1995.
- IMSS, Reglamento del seguro de salud para la familia, México, 1997.
- IMSS, Reglamento para el trámite y resolución de las quejas administrativas ante el Instituto Mexicano del Seguro Social, México, 1997.
- IMSS, *Lineamientos Estratégicos 1996-2000*, IMSS, México, 1996.
- Izquierdo, Ma. Teresa, *El Economista*, 30 de abril de 1999.
- Kaufman, Robert R., Approaches to the Study of State Reform in Latin American countries and Postsocialist Countries, *Comparative Politics*, pp. 357-378, April 1999.
- La Jornada*, 2 de noviembre de 1995, 25 de noviembre de 1995.
- Laurell, Ana Cristina, *Ley Privatizadora y sin consenso*, en *La Jornada Laboral* No.59, pag.3, 8 de diciembre de 1995.
- Laurell, Asa Cristina (coord.), Nuevas tendencias y alternativas en el sector salud, Universidad Autónoma Metropolitana, Unidad Xochimilco y Fundación Friedrich Ebert, México: 1994.
- Madrid, Raúl, The politics of sweeping reform: pension privatization in Mexico in the 1990s Dept. of Political Science, Stanford University, (mimeo), 1998.
- Márquez, Viviane "Estructura del sector público de la salud en México: problemas y perspectivas", El Colegio de México, Centro de Estudios Sociológicos, Ponencia preparada para el V Congreso de Trabajo Social del 2 al 4 de abril de 1981 en la Ciudad de México.
- Nueva Ley del Seguro Social Comentada, IMSS, Tomo III, México, 1998.
- Poder Ejecutivo Federal, Plan Nacional de Desarrollo 1995-2000, México, 1995.
- Poder Ejecutivo Federal, Programa de Reforma del Sector Salud 1995-2000, México.
- Presentación al C. presidente de la República, Ernesto Zedillo Ponce de León, de la Propuesta Obrero-empresarial de Alianza para el Fortalecimiento y Modernización de la Seguridad Social, 1° de noviembre de 1995.
- Programa y Convenio de Fortalecimiento Financiero 1998-2000, Dirección de Planeación y Finanzas, Versión ejecutiva, IMSS, México, 1998.
- Reforma, 2 de mayo de 1999, Barranco Echavarría: Balance General; 26 de abril de 1999.
- Reglamento de Servicios Médicos, "Modelo de Medicina de Familia", 23 de octubre de 1996.
- Salud para todos los mexicanos, Líneas estratégicas para un programa de salud 1994-2000, Grupo Asesor en Salud (SSA-SHCP-CEDESS-FUNSAUD), 23 de noviembre de 1994.
- Smith, Martin J., Pressure, Power and Policy: State Autonomy and Policy Networks in Britain and the United States, Harvester Wheatsheaf, Great Britain, 1993.
- Velázquez, Carlos, Salud, el sector privado y las OASS, *El Economista*, 22 de marzo de 1999.
- Ward, Peter, "Social welfare policy and political opening in Mexico" en Wayne Cornelius et. al. Transforming State-society relations in Mexico: The National Solidarity strategy, San Diego: Center for U.S.-Mexican Studies, UCSD, 1994.

III. CHANGE TEAM AND OTHER POLITICAL STRATEGIES

- Conaghan, Catherine M. et al., "Business and the 'Boys': The Politics of Neoliberalism in the Central Andes", in *Latin American Research Review*, Vol. 25, No. 2, 1990.
- Geddes, Barbara, "The Politics of Economic Liberalization", in *Latin American Research Review*, Vol. 30, No. 2, 1995.
- Haggard, Stephan; Kaufman, Robert (eds.), The Politics of Economic Adjustment, Princeton University Press, introduction, Chapters 4, 5, Princeton, New Jersey, 1992.
- Huneus, Carlos, Tecnócratas y Políticos en un Régimen Autoritario: Los 'ODEPLAN Boys' y los 'Gremialistas en el Chile de Pinochet', MIMEO, 1997.
- Rehren, Alfredo, La Organización de la Presidencia y el Proceso Político Chileno, MIMEO, 1996.
- Schneider, Ben Ross, "The Career Connection: A Comparative Analysis of Bureaucratic Preferences and Insulation" in *Comparative Politics*, 1993.
- Schneider, Ben Ross, Politics within the State: Elite Bureaucrats and Industrial Policy in Authoritarian Brazil, University of Pittsburgh Press, Pittsburgh, 1991.
- Silva, Patricio, "Technocrats and Politics in Chile: from the Chicago Boys to the CIEPLAN Monks", *Journal of Latin American Studies*, Vol. 23, No. 2, May 1991.
- Smith, Martin J., Pressure Power & Policy: State Autonomy and Policy Networks in Britain and the United States, Harvester Wheatsheaf, Great Britain, 1993.
- Walt, Gill, Health Policy: An Introduction to Process and Power, Zed Books, London, UK, 1994.